

RI360P0-QR24M0-ELIU5X2-H1151 Contactless Encoder – Analog Premium Line

Features

- Compact, rugged housing
- Many mounting possibilities
- Status displayed via LED
- Measuring range indicated via LED
- Immune to electromagnetic interference
- Measuring range programmable via Easy Teach
- Output signal programmable via Easy Teach
- Resolution, 16-bit
- 15...30 VDC
- 0...10 V and 4...20 mA
- Male M12 x 1, 5-pin

Wiring diagram

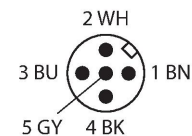
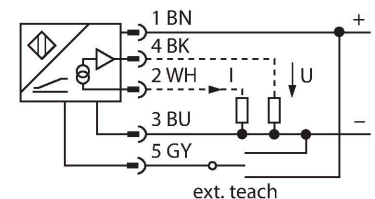

Functional principle

The measuring principle of inductive angle sensors is based on oscillation circuit coupling between the positioning element and the sensor, whereby an output signal is provided proportional to the angle of the positioning element. The rugged sensors are wear and maintenance-free, thanks to the contactless operating principle. They convince through their excellent repeatability, resolution and linearity within a broad temperature range. The innovative technology ensures a high immunity to electromagnetic DC and AC fields.

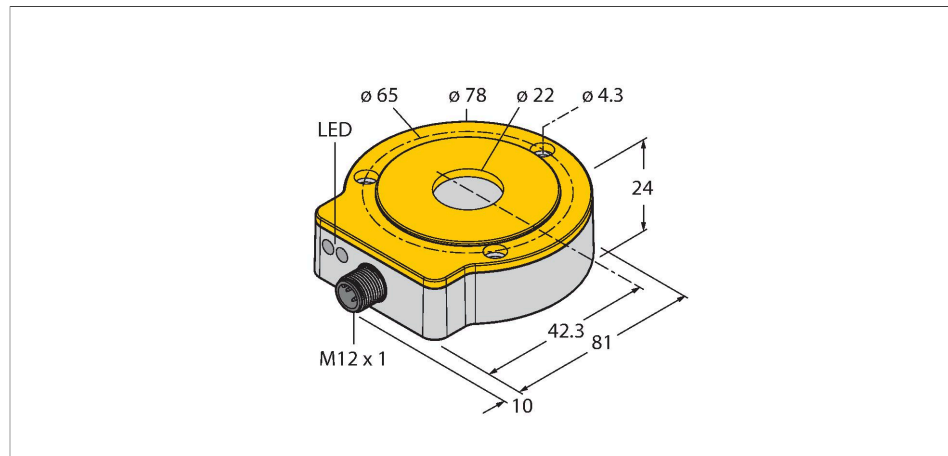

Technical data

Type	RI360P0-QR24M0-ELIU5X2-H1151
Ident. no.	1590908
Measuring principle	Inductive
Max. Rotational Speed	12000 rpm
	Determined with standardized construction, with a steel shaft \varnothing 20 mm, L = 50 mm and reducer \varnothing 20 mm
Starting torque shaft load (radial / axial)	not applicable, because of contactless measuring principle
Resolution	16 bit
Measuring range	0...360°
Nominal distance	1.5 mm
Repeat accuracy	$\leq 0.01\%$ of full scale
Linearity deviation	$\leq 0.05\%$ f.s.
Temperature drift	$\leq \pm 0.004\%$ / K
Ambient temperature	-25...+85 °C
Operating voltage	15...30 VDC
Residual ripple	$\leq 10\%$ U_{ss}
Isolation test voltage	≤ 0.5 kV
Short-circuit protection	yes
Wire breakage/Reverse polarity protection	yes / yes (voltage supply)
Output type	absolute singleturn
Resolution singleturn	16 Bit
Output function	5-pin, Analog output

Technical data

Voltage output	0...10 V
Current output	4...20 mA
Diagnostic	Positioning element not within detection range: Output signal 24mA or 11 V
Load resistance voltage output	≥ 4.7 kΩ
Load resistance, current output	≤ 0.4 kΩ
Sample rate	5000 Hz
Current consumption	< 50 mA
Design	QR24
Dimensions	81 x 78 x 24 mm
Flange type	Flange without mounting element
Shaft Type	Hollow shaft
Shaft diameter D [mm]	6 6.35 9.525 10 12 12.7 14 15.875 19.05 20
Housing material	Metal/plastic, ZnAlCu1/PBT-GF30-V0
Electrical connection	Connector, M12 × 1
Vibration resistance	55 Hz (1 mm)
Vibration resistance (EN 60068-2-6)	20 g; 10...3000 Hz; 50 cycles; 3 axes
Shock resistance (EN 60068-2-27)	100 g; 11 ms ½ sinus; each 3x; 3 axes
Continuous shock resistance (EN 60068-2-29)	40 g; 6 ms ½ sinus; each 4000 x; 3 axes
Protection class	IP68 / IP69K
MTTF	138 years acc. to SN 29500 (Ed. 99) 40 °C
Power-on indication	LED, Green
Measuring range display	LED, yellow, yellow flashing

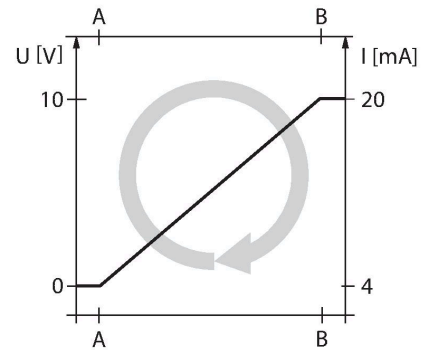

Mounting instructions

Mounting instructions/Description

A

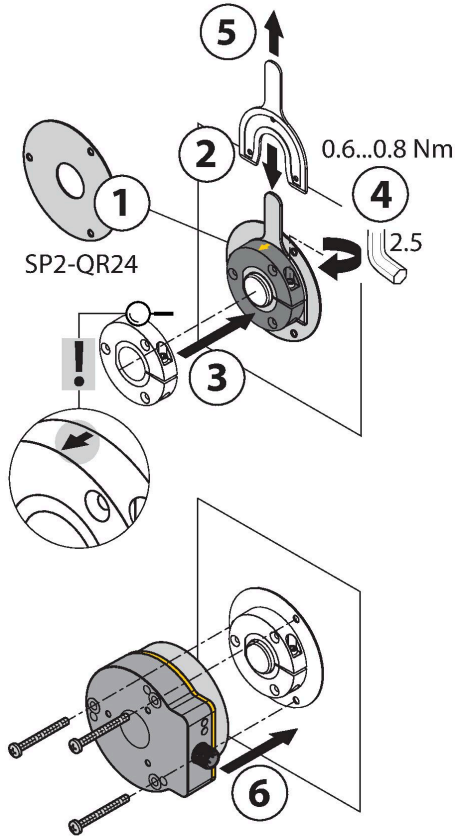

B

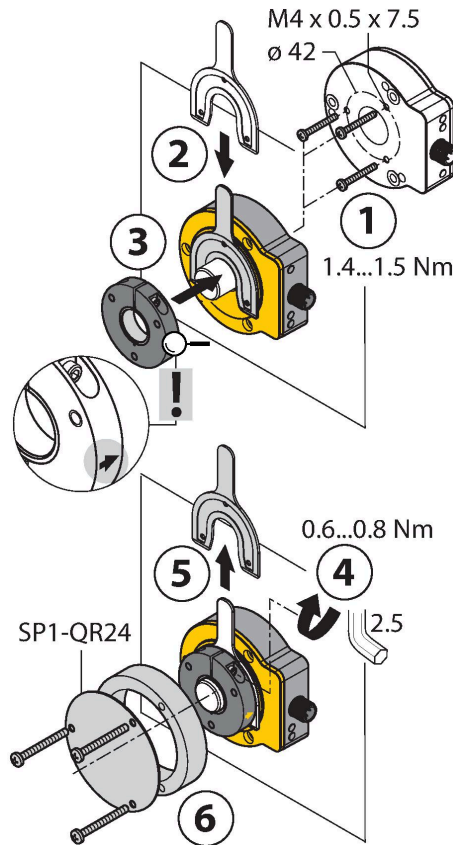

Extensive range of mounting accessories for easy adaptation to many different shaft diameters. Based on the functional principle of RLC coupling, the sensor operates absolutely wear-free and is immune to magnetized metal splinters and other interference fields. Wrong installation is hardly possible.

The adjacent figure shows the two separate units, sensor and positioning element.

Mounting option A:

First, interconnect positioning element and rotatable shaft. Then place the encoder above the rotating part in such a way that you get a tight and protected unit.

Mounting option B:

Push the encoder on the back site of the shaft and fasten it to the machine. Then clamp the positioning element to the shaft with the bracket.

Mounting option C:

If the positioning element is to be screwed on a rotating machine part, use the RA0-QR24 plug which is included in the delivery. Then tie up the bracket. Screw on the encoder via the three bores.

The separately arranged sensor and positioning element inhibit that compensating currents or damaging mechanical loads are transmitted via the shaft to the sensor. In addition, the encoder remains tight and highly protected during its entire lifespan.

The accessories enclosed in the delivery help to mount encoder and positioning element at an optimal distance from each other. LEDs indicate the switching status.

Status display via LED

green steady:

Optimal sensor supply

yellow steady:

Positioning element has reached the end of the measuring range. This is indicated by a lower signal quality.

yellow flashing:

Positioning element is outside the measuring range.

off:

Positioning element is in the measuring range.

C

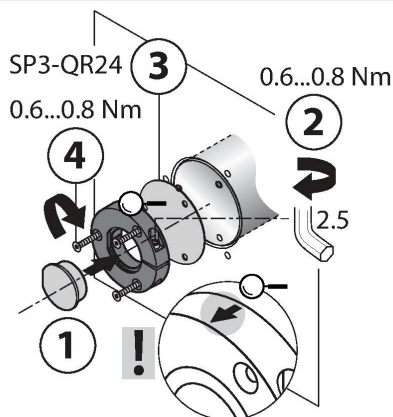

Default: 0°

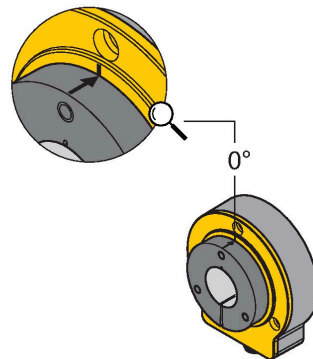

Individual Parameterization (Teaching with Positioning Element)

Bridge between teach input Pin 5 (GY)	Gnd Pin 3 (BU)	Ub Pin1 (BN)	LED
2 s	Start value	End value	Status LED flashes then turns steady after 2 s
10 s	CCW rotation, then return to last preset value	CW rotation, then return to last preset value	After 10 s status LED flashes fast for 2 s
15 s	-	Factory setting (360°, CW)	after 15 s power and status LED alternate

To avoid unintended teaching, keep pin 5 potential-free.

Preset Parameterization (Teaching without Positioning Element)

Bridge pin between teach input Pin 5 (GY)	Gnd Pin 3 (BU)	Ub Pin 1 (BN)	LED
2 s	Activate selection mode for output signal (for 10 s)	Activate preset mode (for 10 s)	Status LED steady, flashes after 2 s
10 s	CCW rotation direction	CW rotation direction	After 10 s status LED flashes fast for 2 s
15 s		Factory setting (360°, CW)	After 15 s power and status LED flash equally fast
Output configuration	Gnd Pin 3 (BU)		Status LED
I out: 4...20 mA	Press once		1 x flashing
I out: 0...20 mA	Press twice		2 x flashing
Uout: 0...10 V	Press three times		3 x flashing
Uout: 0...5 V	Press four times		4 x flashing
Uout: 0.5 V / 4.5 V	Press five times		5 x flashing
Preset mode / Angular range		Ub Pin 1 (BN)	Status LED
45°		Press once	1 x flashing
60°		Press twice	2 x flashing
90°		Press three times	3 x flashing
180°		Press four times	4 x flashing
270°		Press five times	5 x flashing

To avoid unintended teaching, keep pin 5 potential-free.

Accessories

P1-RI-QR24 1590921

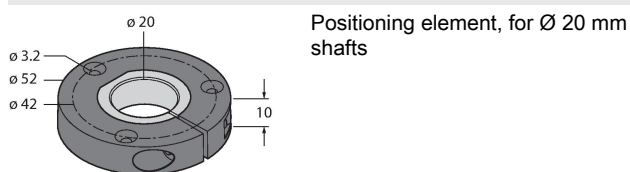

P2-RI-QR24 1590922

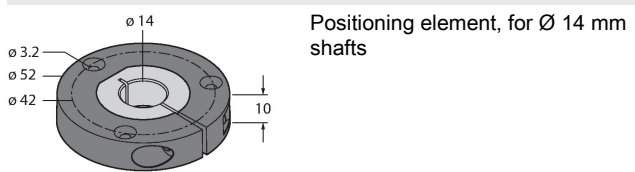

P3-RI-QR24 1590923

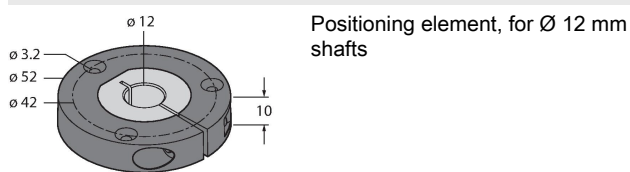

P4-RI-QR24 1590924

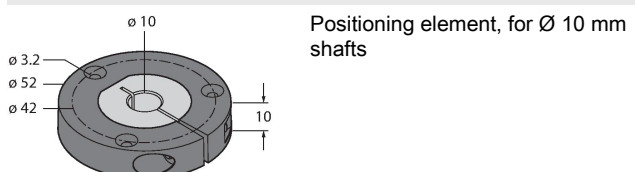

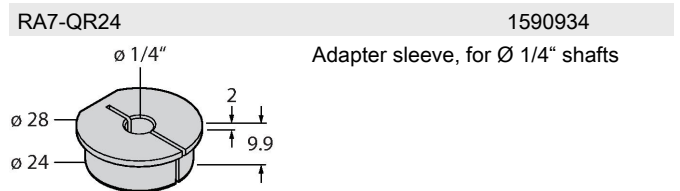
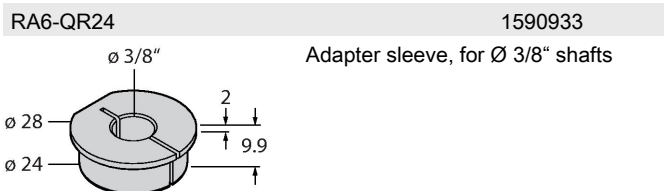
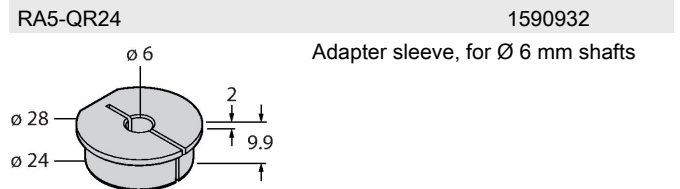
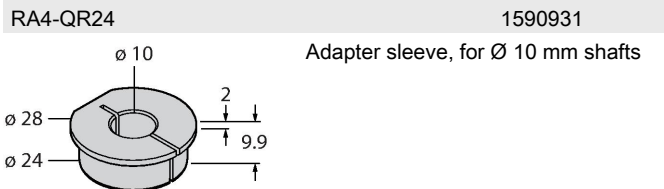
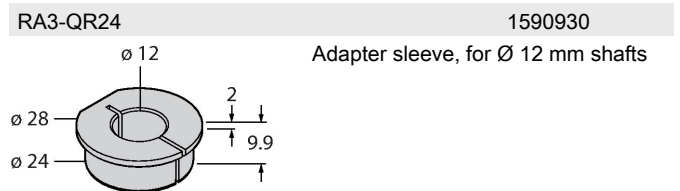
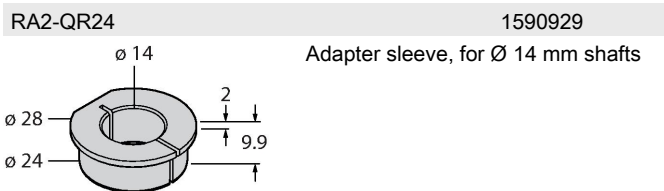
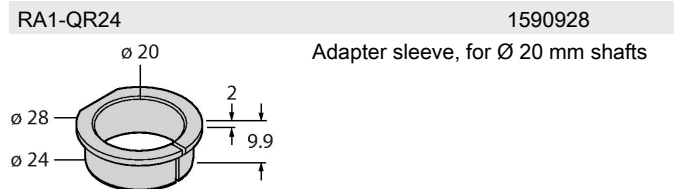
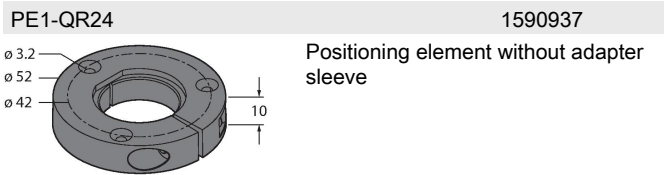
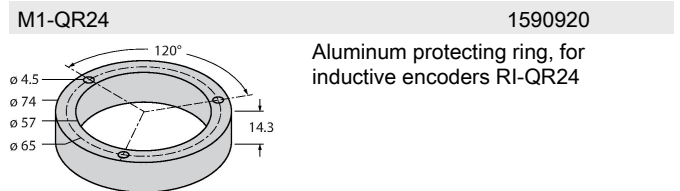
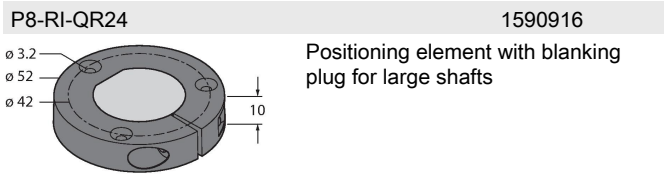
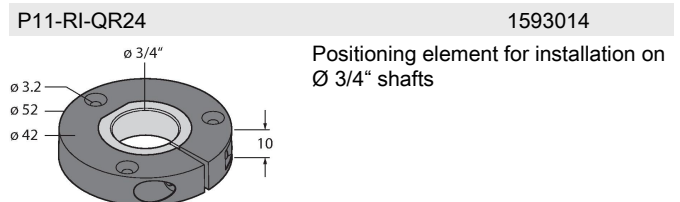
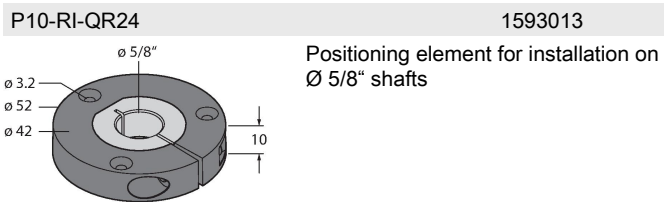
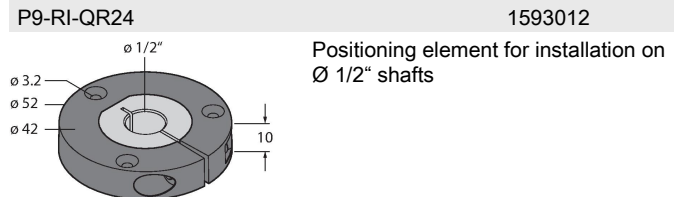
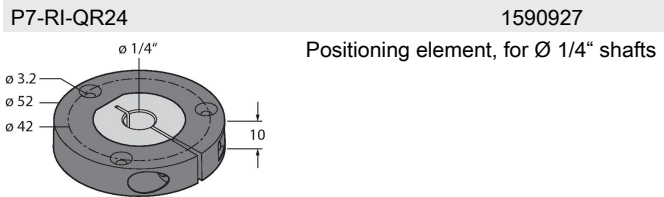
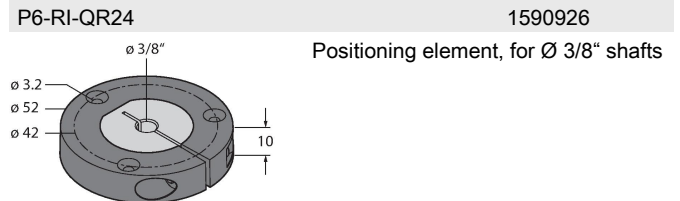
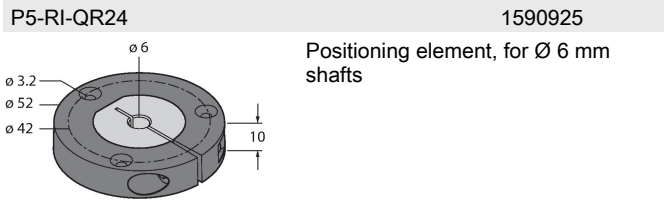

RA9-QR24 1590960 Adapter sleeve, for Ø 1/2" shafts

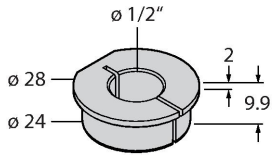

RA10-QR24 1590961 Adapter sleeve, for Ø 5/8" shafts

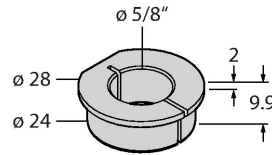

RA11-QR24 1590962 Adapter sleeve, for Ø 3/4" shafts

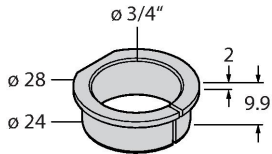

RA8-QR24 1590959 Plug for mounting option C

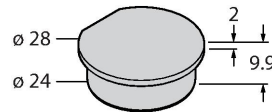

SP1-QR24 1590938 Shield plate Ø 74 mm, aluminium

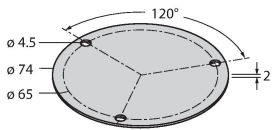

SP2-QR24 1590939 Shield plate Ø 74 mm, aluminium, with borehole for shaft feedthrough

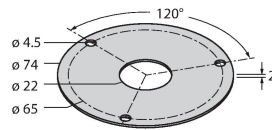

SP3-QR24 1590958 Shield plate Ø 52 mm, aluminium

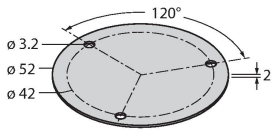

MT-QR24 1590935 Mounting aid for optimal alignment of positioning element

