

THIS DOCUMENT IS THE PROPERTY OF  
KEYSTONE ELECTRONICS CORP. AND  
SHALL NOT BE REPRODUCED, DISTRIBUTED  
OR USED AS A BASIS FOR MANUFACTURE  
WITHOUT PRIOR WRITTEN PERMISSION  
FROM KEYSTONE ELECTRONICS CORP.

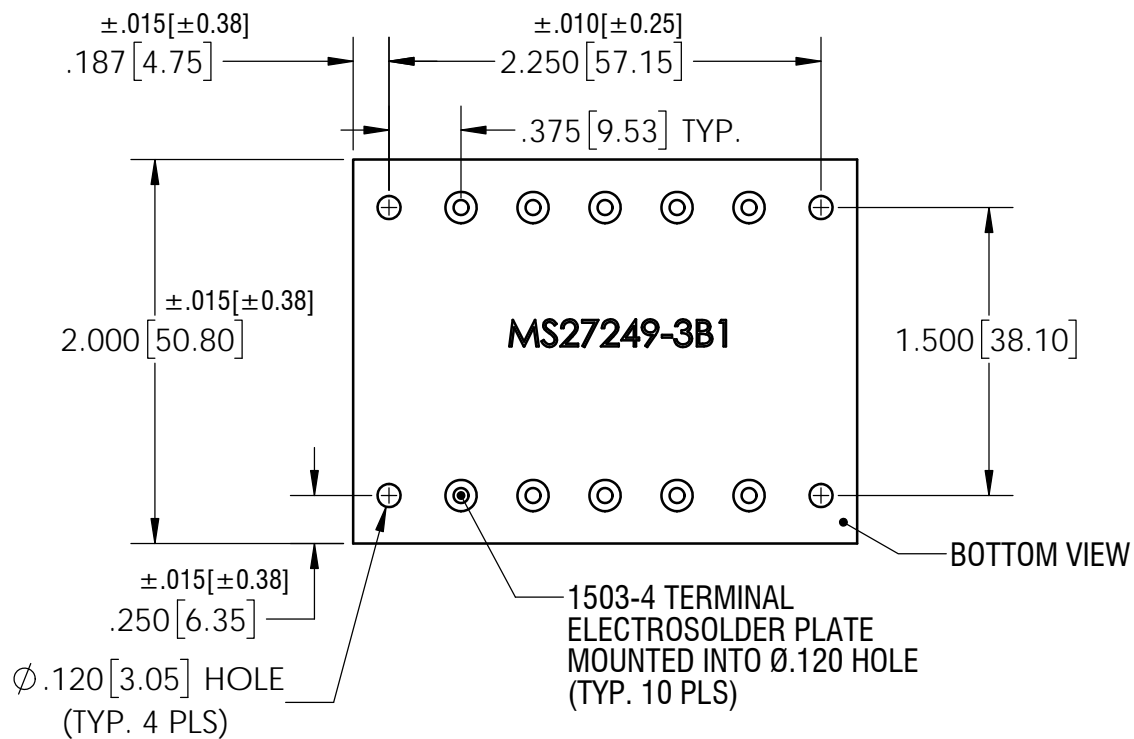
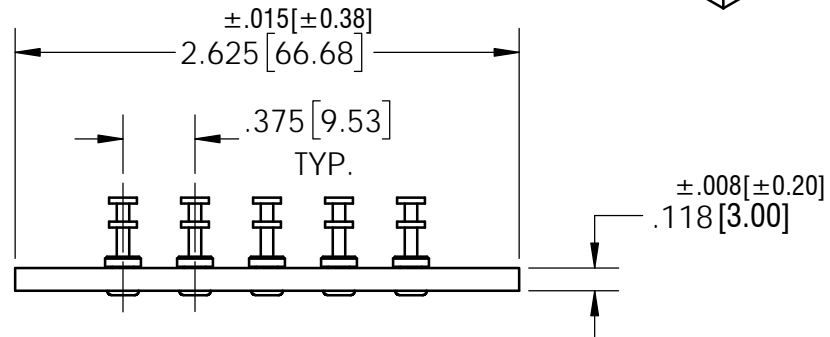
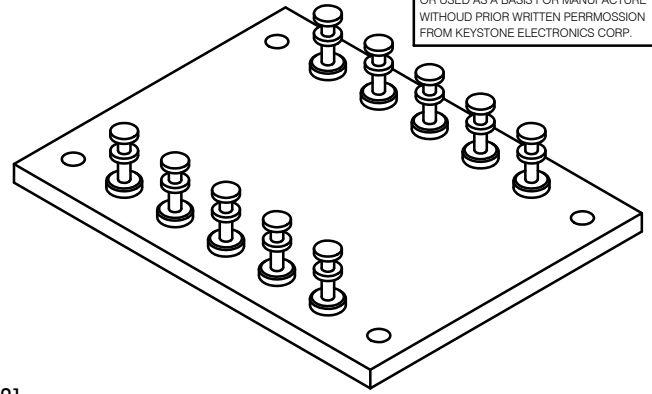

**NOTE:**

1. STAMP P/N: MS27249-3B1 APPROX. AS SHOWN.

<b>KEYSTONE ELECTRONICS CORP.</b>			
www.keystone.com ● NEW HYDE PARK, NY 11040 ● Tel (516) 328-7500			
PART NAME		TERMINAL BOARD, (1) SECTION	
MATERIAL		.118 [3.00] TH'K G-11 GLASS EPOXY	
FINISH		DRN BY	DATE
NONE		BOONE	9.27.93
		APP'D	SCALE
		RH	1X
TOLERANCES	INCH	[MM]	CODE
DECIMAL	±.005	[±0.13]	DWG NO.
ANGULAR	±1°		<b>MS272493B1</b>
UNLESS OTHERWISE SPECIFIED			

DATE	DESCRIPTION	REV.