





APPLICABLE STANDARD					
RATING	OPERATING TEMPERATURE RANGE	-25 °C TO +85 °C	STORAGE TEMPERATURE RANGE	-10 °C TO +60 °C	
	VOLTAGE	AC 350 V , DC 500 V			
	CURRENT	7 A			
SPECIFICATIONS					
ITEM	TEST METHOD		REQUIREMENTS	QT	AT
CONSTRUCTION					
GENERAL EXAMINATION	VISUALLY AND BY MEASURING INSTRUMENT.		ACCORDING TO DRAWING.	X	X
MARKING	CONFIRMED VISUALLY.			X	X
ELECTRIC CHARACTERISTICS					
CONTACT RESISTANCE	CONTACT SHALL BE MEASURED AT DC 1 A		5 mΩ MAX.	X	X
INSULATION RESISTANCE	500 V DC.		1000 MΩ MIN.	X	X
VOLTAGE PROOF	1000 V AC. FOR 1 min.		NO FLASHOVER OR BREAKDOWN.	X	X
MECHANICAL CHARACTERISTICS					
CONTACT INSERTION AND WITHDRAWAL FORCES	— BY STEEL GAUGE.		INSERTION AND WITHDRAWAL FORCES : —	—	—
CONNECTOR INSERTION AND WITHDRAWAL FORCES	MEASURED BY APPLICABLE CONNECTOR.		INSERTION AND WITHDRAWAL FORCES LOCKING DEVICE WITH UNLOCK : 35 N MAX.	X	—
MECHANICAL OPERATION	1000 TIMES INSERTIONS AND EXTRACTIONS.		CONTACT RESISTANCE: 5 mΩ MAX.	X	—
VIBRATION	FREQUENCY : 10 → 55 → 10(Hz) , SINGLE AMPLITUDE 0.75 mm. AT 2h, FOR 3 DIRECTIONS.		① NO ELECTRICAL DISCONTINUITY OF 10 μs. ② NO DAMAGE, CRACK AND LOOSENESS, OF PARTS.	X	—
SHOCK	IN OPPOSITE DIRECTIONS OF EACH 3 DEMENSION AXIS FOR 3 TIMES AT 490 m/s ² DURATIONS OF PULSE 11 ms.		① NO ELECTRICAL DISCONTINUITY OF 10 μs. ② NO DAMAGE, CRACK AND LOOSENESS, OF PARTS.	X	—
ENVIRONMENTAL CHARACTERISTICS					
DAMP HEAT (STEADY STATE)	EXPOSED AT 40 °C, 90 TO 95 %, 96 h.		① INSULATION RESISTANCE: 10 MΩ MIN (AT HIGH HUMIDITY). ② INSULATION RESISTANCE: 100 MΩ MIN (AT DRY). ③ NO DAMAGE, CRACK AND LOOSENESS OF PARTS.	X	—
RAPID CHANGE OF TEMPERATURE	TEMPERATURE -55 → R/T ⁽¹⁾ → +85 → R/T °C TIME 30 → 10 TO 15 → 30 → 10 TO 15 min UNDER 5 CYCLES.		① INSULATION RESISTANCE: 1000 MΩ MIN.  ② NO DAMAGE, CRACK AND LOOSENESS OF PARTS.	X	—
CORROSION SALT MIST	EXPOSED IN 5 % SALT WATER SPRAY FOR 48 h.		NO HEAVY CORROSION RUIN THE FUNCTION.	X	—
DRY HEAT	EXPOSED AT + 85 °C , 96 h.		NO DAMAGE, CRACK AND LOOSENESS OF PARTS.	X	—
COLD	EXPOSED AT - 55 °C , 96 h.		NO DAMAGE, CRACK AND LOOSENESS OF PARTS.	X	—
RESISTANCE TO SOLDERING HEAT	SOLDERED AT SOLDERING IRON BIT TEMPERATURE +380±10°C FOR 3 ⁺¹ ₀ s.		NO DEFORMATION OF CASE OF EXCESSIVE LOOSENESS OF THE TERMINALS.	X	—
SOLDERABILITY	SOLDERED AT SOLDERING IRON BIT TEMPERATURE +350±10°C FOR 2 TO 3 s.		WETTING ON SOLDER SURFACE. NO SOLDER CLUSTER.	X	—
	COUNT	DESCRIPTION OF REVISIONS	DESIGNED	CHECKED	DATE
	1	DIS-C-00000966	HY. KISHI	HY. KOBAYASHI	16.05.14
REMARK			APPROVED	HY. KOBAYASHI	15.10.28
NOTE (1) R/T : ROOM TEMPERATURE.			CHECKED	HY. KOBAYASHI	15.10.28
Unless otherwise specified, refer to JIS C 5402. (IEC60512)			DESIGNED	HY. KISHI	15.10.28
			DRAWN	HY. KISHI	15.10.28
Note QT:Qualification Test AT:Assurance Test X:Applicable Test			DRAWING NO.	ELC-119229-00-00	
	SPECIFICATION SHEET		PART NO.	HS16RA-2	
	HIROSE ELECTRIC CO., LTD.		CODE NO.	CL101-0603-0-00	 1/1

A A

B B

C C

D D

E E

F F

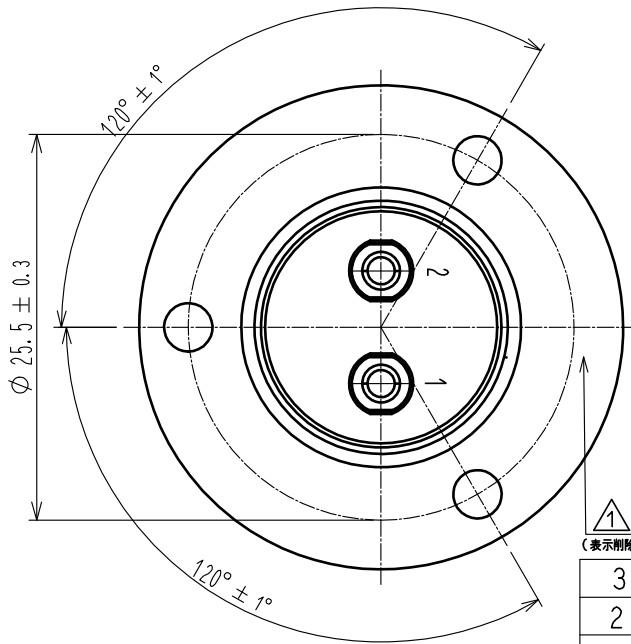
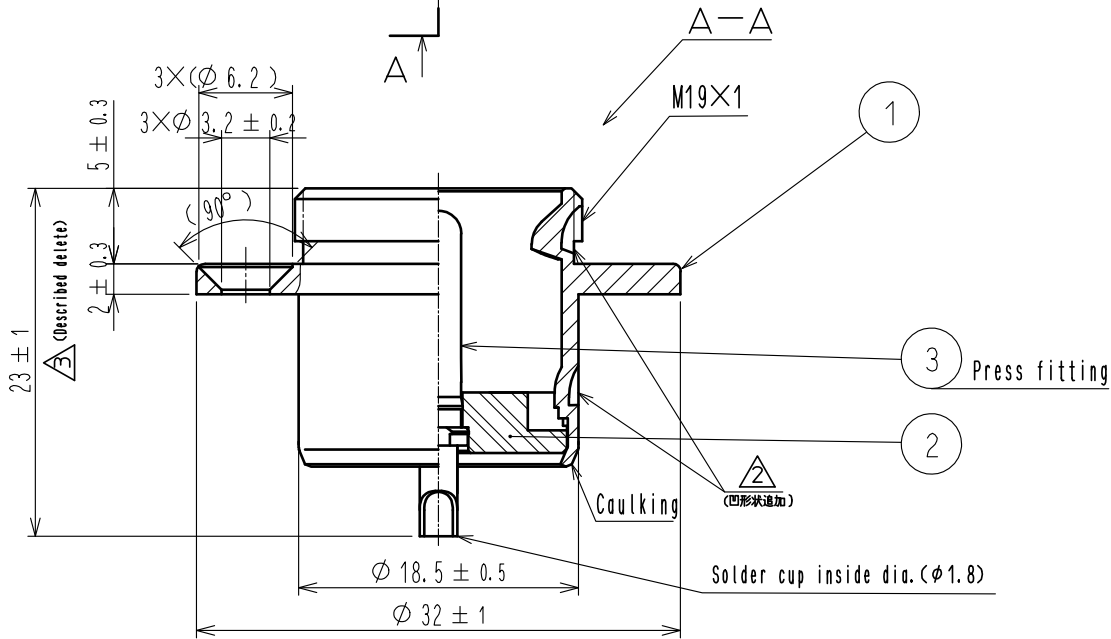
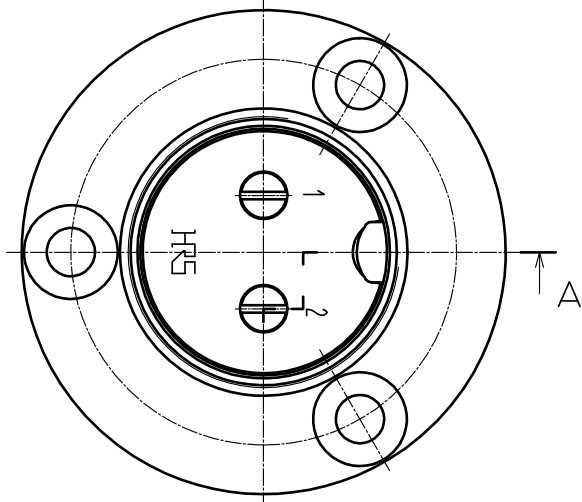

(表示削除)

3	Brass	Nickel plating 0.8μm min.
2	PPS	Black (UL94V-0)
1	Brass	Nickel plating

NO.	MATERIAL	FINISH .	REMARKS	NO.	MATERIAL	FINISH .	REMARKS
UNITS mm		SCALE 2 : 1	COUNT 1	DESCRIPTION OF REVISIONS DIS-C-00000645	DESIGNED HY. KISHI	CHECKED HY. KOBAYASHI	DATE 15.12.09
APPROVED : HY. KOBAYASHI 15.10.28 CHECKED : HY. KOBAYASHI 15.10.28 DESIGNED : HY. KISHI 15.10.28 DRAWN : HY. KISHI 15.10.28				DRAWING NO. EDC-119229-00-00 PART NO. HS16RA-2 CODE NO. CL101-0603-0-00			