

## Positive Thermal Coefficient Diodes

### SMD1206P005~200 Series

The SMD1206 Series PTC provides surface mount overcurrent protection for applications where space is at a premium and resettable protection is desired.

#### Features

- RoHS compliant, lead-free and halogen-free<sup>1</sup>
- Fast response to fault currents
- Compact design saves board space
- Low resistance
- Low-profile
- Compatible with high temperature solders

#### Applications

- USB peripherals
- Disk drives
- CD-ROMs
- Plug and play protection for motherboards and peripherals
- Mobile phones - battery and port protection
- Disk drives
- PDAs / digital cameras
- Game console port protection



#### Dimension

MARKING CODE VARIES  
WITH AMPERAGE RATING  
(See Electrical Characteristic Table)  
SHOWN IS 1.0AMP RATING

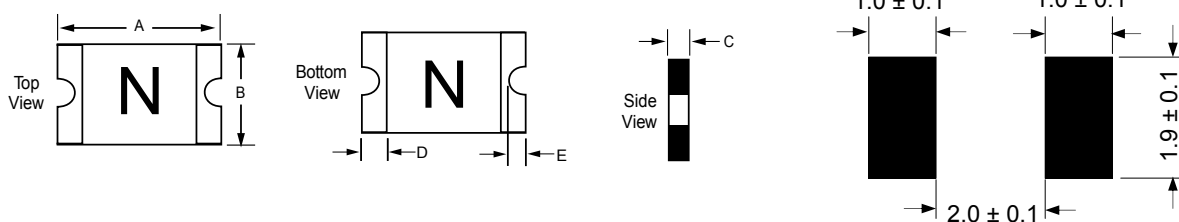

Model	A		B		C		D	E
	Min.	Max.	Min.	Max.	Min.	Max.	Min.	Min.
SMD1206P005TF	3.00	3.50	1.50	1.80	0.60	0.90	0.15	0.10
SMD1206P010TF	3.00	3.50	1.50	1.80	0.60	0.90	0.15	0.10
SMD1206P012TF	3.00	3.50	1.50	1.80	0.60	0.90	0.15	0.10
SMD1206P016TF	3.00	3.50	1.50	1.80	0.50	0.90	0.15	0.10
SMD1206P020TF	3.00	3.50	1.50	1.80	0.40	0.90	0.15	0.10
SMD1206P025TF	3.00	3.50	1.50	1.80	0.40	0.90	0.15	0.10
SMD1206P035TF	3.00	3.50	1.50	1.80	0.40	0.90	0.15	0.10
SMD1206P050TF	3.00	3.50	1.50	1.80	0.35	0.90	0.15	0.10
SMD1206P050TF/13.2	3.00	3.50	1.50	1.80	0.35	0.90	0.15	0.10
SMD1206P075TF	3.00	3.50	1.50	1.80	0.30	1.00	0.15	0.10
SMD1206P075TF/13.2	3.00	3.50	1.50	1.80	0.30	1.00	0.15	0.10
SMD1206P100TF	3.00	3.50	1.50	1.80	0.40	1.30	0.15	0.10
SMD1206P150TF	3.00	3.50	1.50	1.80	0.50	1.30	0.15	0.10
SMD1206P175TF	3.00	3.50	1.50	1.80	0.50	1.40	0.15	0.10
SMD1206P200TF	3.00	3.50	1.50	1.80	0.50	1.40	0.15	0.10

## Electrical Characteristics

Type Number	I <sub>hold</sub>	I <sub>trip</sub>	V <sub>max</sub>	I <sub>max</sub>	P <sub>d</sub> max.	Maximum Time To Trip		Resistance	
	(A)	(A)	V <sub>(dc)</sub>	(A)	(W)	Current (A)	Time (Sec.)	R <sub>min</sub> (Ω)	R <sub>1max</sub> (Ω)
SMD1206P005TF	0.05	0.15	60	100	0.4	0.3	1.50	3.600	50.00
SMD1206P010TF	0.10	0.25	60	100	0.4	0.5	1.00	1.600	15.00
SMD1206P012TF	0.12	0.29	60	100	0.4	0.5	1.00	1.600	15.00
SMD1206P016TF	0.16	0.37	30	100	0.6	8.0	0.08	0.350	2.50
SMD1206P020TF	0.20	0.46	24	100	0.6	8.0	0.08	0.350	2.50
SMD1206P025TF	0.25	0.50	16	100	0.6	8.0	0.10	0.250	1.30
SMD1206P035TF	0.35	0.75	6	100	0.6	8.0	0.10	0.150	0.70
SMD1206P050TF	0.50	1.00	6	100	0.6	8.0	0.10	0.150	0.70
SMD1206P050TF/13.2	0.50	1.00	13.2	100	0.6	8.0	0.10	0.150	0.70
SMD1206P075TF	0.75	1.50	6	100	0.6	8.0	0.20	0.090	0.50
SMD1206P075TF/13.2	0.75	1.50	13.2	100	0.6	8.0	0.20	0.090	0.50
SMD1206P100TF	1.00	1.80	6	100	0.6	8.0	0.30	0.055	0.27
SMD1206P150TF	1.50	3.00	6	100	0.8	8.0	0.30	0.040	0.13
SMD1206P175TF	1.75	3.50	6	100	0.8	8.0	0.50	0.020	0.09
SMD1206P200TF	2.00	3.50	6	100	0.8	8.0	1.50	0.018	0.08

I<sub>hold</sub> = Hold current: maximum current device will pass without tripping in 23°C still air.

I<sub>trip</sub> = Trip current: minimum current at which the device will trip in 23°C still air.

V<sub>max</sub> = Maximum voltage device can withstand without damage at rated current (I<sub>max</sub>)

I<sub>max</sub> = Maximum fault current device can withstand without damage at rated voltage (V<sub>max</sub>)

P<sub>d</sub> = Power dissipated from device when in the tripped state at 23°C still air.

R<sub>min</sub> = Minimum resistance of device in initial (un-soldered) state.

R<sub>typ</sub> = Typical resistance of device in initial (un-soldered) state.

R<sub>1max</sub> = Maximum resistance of device at 23°C measured one hour after tripping or reflow soldering of 260°C for 20 sec.

## Thermal Derating Chart-IH(A)

Model	Maximum ambient operating temperature (T <sub>mao</sub> ) vs. hold current (I <sub>hold</sub> )								
	-40°C	-20°C	0°C	23°C	40°C	50°C	60°C	70°C	85°C
SMD1206P005TF	0.080	0.070	0.060	0.050	0.040	0.040	0.030	0.030	0.020
SMD1206P010TF	0.145	0.130	0.115	0.100	0.085	0.075	0.070	0.060	0.055
SMD1206P012TF	0.170	0.150	0.140	0.120	0.100	0.900	0.080	0.070	0.070
SMD1206P016TF	0.220	0.200	0.180	0.160	0.140	0.120	0.100	0.090	0.080
SMD1206P020TF	0.290	0.260	0.230	0.200	0.170	0.150	0.140	0.120	0.110
SMD1206P025TF	0.370	0.330	0.290	0.250	0.220	0.200	0.170	0.150	0.120
SMD1206P035TF	0.500	0.450	0.400	0.350	0.300	0.270	0.240	0.210	0.150
SMD1206P050TF	0.710	0.640	0.570	0.500	0.420	0.390	0.350	0.310	0.250
SMD1206P050TF/13.2	0.710	0.640	0.570	0.500	0.420	0.390	0.350	0.310	0.250
SMD1206P075TF	1.140	1.010	0.880	0.750	0.650	0.590	0.540	0.490	0.410
SMD1206P075TF/13.2	1.140	1.010	0.880	0.750	0.650	0.590	0.540	0.490	0.410
SMD1206P100TF	1.450	1.310	1.150	1.000	0.840	0.770	0.690	0.610	0.480
SMD1206P150TF	2.180	1.940	1.720	1.500	1.280	1.170	1.060	0.960	0.770
SMD1206P175TF	2.500	2.250	2.000	1.750	1.550	1.450	1.350	1.250	1.100
SMD1206P200TF	2.880	2.630	2.340	2.000	1.740	1.580	1.420	1.370	1.130

## Recommended Solder Reflow Conditions

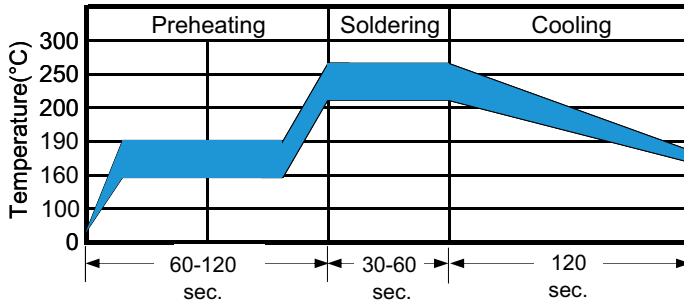

- Recommended reflow methods : IR, vapor phase oven, hot air oven.
  - Devices are not designed to be wave soldered to the bottom side of the board.
  - Recommended maximum paste thickness is 0.25 mm (0.010 inch).
  - Devices can be cleaned using standard method and solvents.
- Note : If reflow temperatures exceed the recommended profile, devices may not meet the performance requirements.

## Tape And Reel Specifications (mm)

Governing Specifications	EIA 481-1
W	8.15 ± 0.3
P <sub>0</sub>	4.0 ± 0.10
P <sub>1</sub>	4.0 ± 0.10
P <sub>2</sub>	2.0 ± 0.05
A <sub>0</sub>	1.95 ± 0.10
B <sub>0</sub>	3.45 ± 0.10
B <sub>1max.</sub>	4.35
D <sub>0</sub>	1.5 + 0.1, -0
F	3.5 ± 0.05
E <sub>1</sub>	1.75 ± 0.10
E <sub>2min.</sub>	6.25
Tmax.	0.6
T <sub>1max.</sub>	0.1
K <sub>0</sub>	1.04 ± 0.1
Leader min.	390
Trailer min.	160
Reel Dimensions	
A max.	178
N min.	60
W <sub>1</sub>	9 ± 0.5
W <sub>2</sub>	12.6 ± 0.5

## Storage And Handling

- Storage conditions : 40°C max, 70% R.H.
- Devices may not meet specified performance if storage conditions are exceeded.

## Order Information

## Packaging

SMD1206□	075	Tape & Reel Quantity	
Product name	Hold	005,010,012,150,200	3,500 pcs/reel
Size 3216 mm / 1206 mils	Current	020,025,035,050,075,100	5,000 pcs/reel
SMD : surface mount device	0.75A		

Tape & reel packaging per EIA481-1

## EIA Tape Component Dimensions

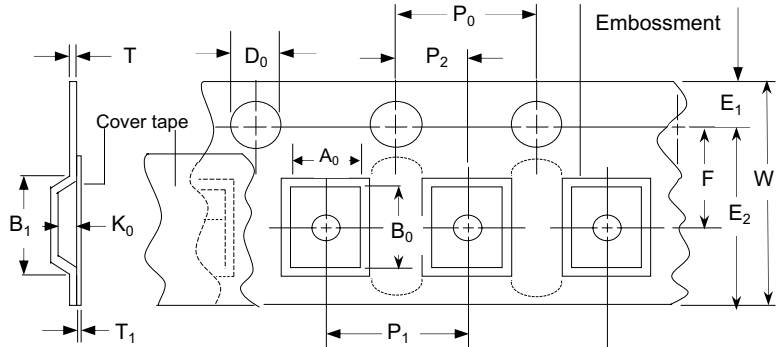

## EIA Reel Dimensions

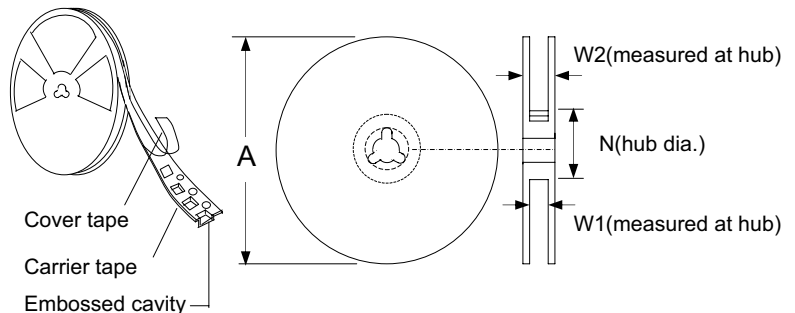

Leiditech Electronics are trademarks.

Information furnished is believed to be accurate and reliable. However, users should independently evaluate the suitability of and test each product selected for their own applications. Leiditech Electronics reserves the right to change or update, without notice, any information contained in this publication; to change, without notice, the design, construction, processing, or specification of any product; and to discontinue or limit production or distribution of any product. This publication supersedes and replaces all information previously supplied. Without expressed or written consent by an officer of Leiditech Electronics, Leiditech Electronics does not authorize the use of any of its products as components in nuclear facility applications, aerospace, or in critical life support devices or systems. Leiditech Electronics expressly disclaims all implied warranties regarding the information contained herein, including, but not limited to, any implied warranties of merchantability or fitness for a particular purpose. Leiditech Electronics' only obligations are those in the Leiditech Electronics Standard Terms and Conditions of Sale and in no case will Leiditech Electronics be liable for any incidental, indirect, or consequential damages.

SHANGHAI LEIDITECH ELECTRONICS CO.,LTD

Tel: +86- 021 50828806

Fax: +86- 021 50477059-8008

Email: sale1@leiditech.com