

# LESD11D3.3CT5G ESD PROTECTION DIODE

## Discription

The LESD11D3.3CT5G is designed to protect voltage sensitive components from ESD. Excellent clamping capability, low leakage, and fast response time make these parts ideal for ESD protection on designs where board space is at a premium. Because of its small size, it is suited for use in cellular phones, digital cameras and many other portable applications where board space is at a premium.

## Applications

- I Cellular phones audio
- I Digital cameras
- I Portable applications
- I Mobile telephone

## Features

- I Small Body Outline Dimensions: 0.61 mm x 0.31 mm
- I Low Body Height: 0.28 mm
- I Low Leakage
- I Response Time is Typically < 1 ns
- I ESD Rating of Class 3 per Human Body Model
- I IEC61000-4-2 Level 4 ESD Protection
- I These are Pb-Free Devices
- I We declare that the material of product compliance with RoHS requirements and Halogen Free.

LESD11D3.3CT5G

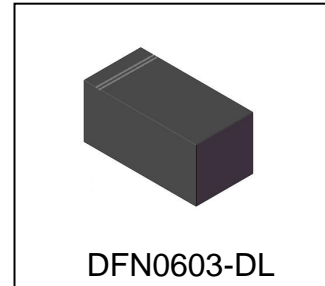

B = Specific Device Code  
M = Month Code

## Ordering information

Device	Marking	Shipping
LESD11D3.3CT5G	B	15000/Tape&Reel

## MAXIMUM RATINGS

Rating	Symbol	Value	Unit
IEC 61000-4-2 (ESD) Air discharge Contact discharge		±25 ±20	kV kV
Total Power Dissipation on FR-5 Board (Note 1) @ T <sub>A</sub> =25°C	PD	200	mW
Junction and Storage Temperature Range	T <sub>J</sub> ,T <sub>STG</sub>	-55 to 150	°C
Lead Solder Temperature – Maximum (10 Second Duration)	TL	260	°C

Stresses exceeding Maximum Ratings may damage the device. Maximum Rating are stress ratings only. Functional operation above the Recommended Operating Conditions is not implied. Extended exposure to stresses above the Recommended Operating Conditions may affect device reliability.

1. FR-5 = 1.0\*0.75\*0.62 in.

# LESD11D3.3CT5G

## ELECTRICAL CHARACTERISTICS

(T<sub>A</sub> = 25°C unless otherwise noted)

Symbol	Parameter
I <sub>PP</sub>	Maximum Reverse Peak Pulse Current
V <sub>C</sub>	Clamping Voltage @ I <sub>PP</sub>
V <sub>RWM</sub>	Working Peak Reverse Voltage
I <sub>R</sub>	Maximum Reverse Leakage Current @ V <sub>RWM</sub>
V <sub>BR</sub>	Breakdown Voltage @ I <sub>T</sub>
I <sub>T</sub>	Test Current
P <sub>pk</sub>	Peak Power Dissipation
C	Capacitance @ V <sub>R</sub> = 0 and f = 1.0 MHz

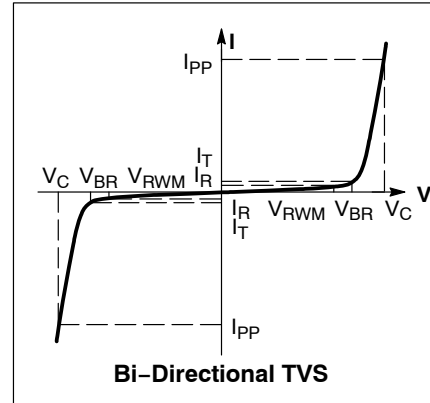

## ELECTRICAL CHARACTERISTICS

Device	V <sub>RWM</sub> (V)	I <sub>R</sub> (μA) @ V <sub>RWM</sub>	V <sub>BR</sub> (V) @ I <sub>T</sub> (Note 2)		I <sub>T</sub>	V <sub>C</sub> (V) @ I <sub>PP</sub> = 1 A (Note 3)	V <sub>C</sub> (V) @ MAX I <sub>PP</sub> (Note 3)	I <sub>PP</sub> (A) (Note 3)	P <sub>PK</sub> (W) (Note 3)	C (pF)
	Max	Max	Min	Max	mA	Max	Max	Max	Max	Max
LESD11D3.3CT5G	3.3	0.1	5.0	6.5	1.0	7	10	6	60	16

Other voltage available upon request.

- V<sub>BR</sub> is measured with a pulse test current I<sub>T</sub> at an ambient temperature of 25°C
- Surge current waveform per Figure 1.

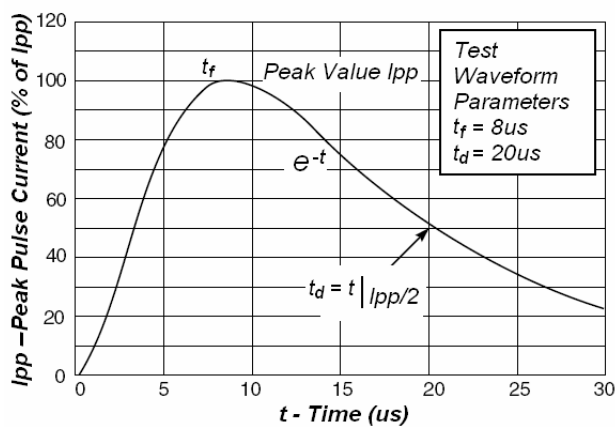

Fig1. Pulse Waveform

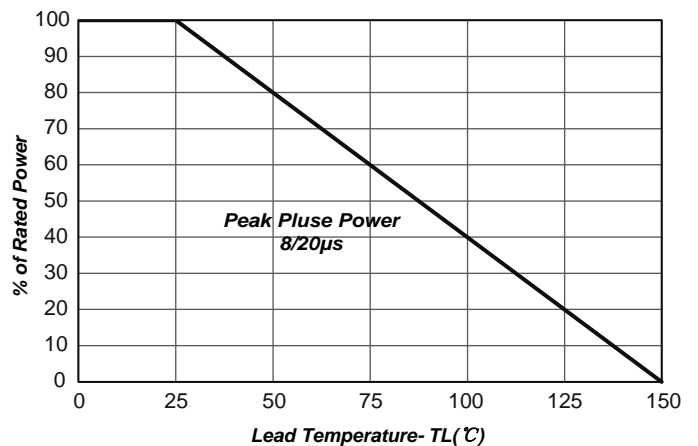

Fig2.Power Derating Curve

# LESD11D3.3CT5G

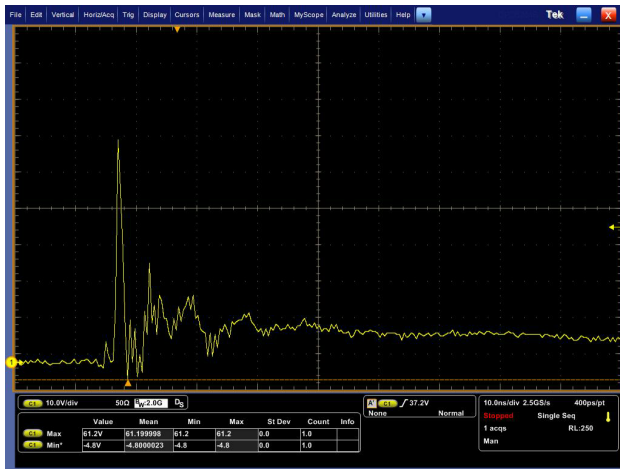

Fig3.Positive 8 kV Contact per IEC61000.4.2



Fig4.Negative 8 kV Contact per IEC61000.4.2

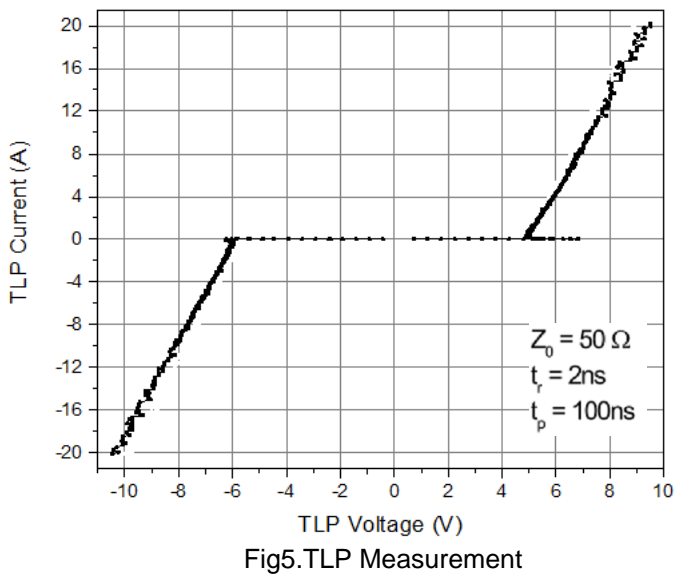
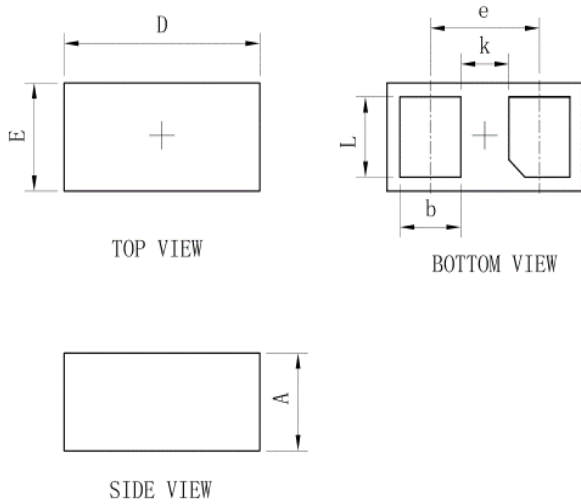

Fig5.TLP Measurement

# LESD11D3.3CT5G

## OUTLINE AND DIMENSIONS



DFN0603-DL			
Dim	Min	Typ.	Max
D	0.58	0.61	0.64
E	0.28	0.31	0.34
e	-	0.34	-
L	0.20	0.23	0.26
b	0.16	0.19	0.22
A	0.25	0.28	0.31
k	0.12	0.15	0.18
All Dimensions in mm			

## SOLDERING FOOTPRINT

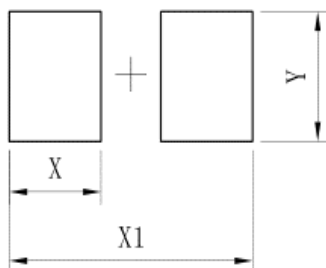

DFN0603-DL	
DIM	(mm)
X	0.23
X1	0.61
Y	0.30

**DISCLAIMER**

- Before you use our Products, you are requested to carefully read this document and fully understand its contents. LRC shall not be in any way responsible or liable for failure, malfunction or accident arising from the use of any LRC's Products against warning, caution or note contained in this document.
- All information contained in this document is current as of the issuing date and subject to change without any prior notice. Before purchasing or using LRC's Products, please confirm the latest information with a LRC sales representative.