

LTVS23LH5.0CLT1G

ESD PROTECTION DIODE

LTVS23LH5.0CLT1G

General Description

The LTVS23LH5.0CLT1G is a Low Capacitance TVS for high speed line protections. The capacitance is lowered by integrating a compensating diode. It clamps the voltage just above the logic level supply for positive transients, and to a diode drop below ground negative transients. And offers ESD protection for high speed interfaces such as communication systems, computers, and computers peripherals.

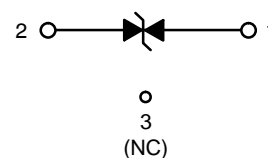
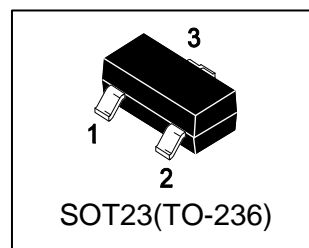

Applications

- Computers
- Printers
- Communication systems

Features

- Low leakage current: $I_{R\max} < 0.5 \mu A$ at VBR
- 300W peak pulse power (8/20 μs)

Benefits

- High ESD protection level
- Suitable for high density boards.

Complies with the following standards

IEC61000-4-2 Level 4

Absolute Ratings ($T_{amb}=25^{\circ}C$)

| Symbol | Parameter | Value | Units |
|-----------|---------------------------------------------------|-------------|-------------|
| P_{PP} | Peak Pulse Power ($t_p = 8/20\mu s$) | 300 | W |
| T_L | Maximum lead temperature for soldering during 10s | 260 | $^{\circ}C$ |
| T_{stg} | Storage Temperature Range | -55 to +150 | $^{\circ}C$ |
| T_{op} | Operating Temperature Range | -40 to +125 | $^{\circ}C$ |
| T_j | Maximum junction temperature | 150 | $^{\circ}C$ |
| V_{PP} | IEC61000-4-2 air discharge | 30 | kv |
| | IEC61000-4-2 contact discharge | 30 | |

Ordering Information

| Device | Marking | Shipping |
|------------------|---------|----------------|
| LTVS23LH5.0CLT1G | H5C | 3000/Tape&Reel |

LTVS23LH5.0CLT1G

ELECTRICAL CHARACTERISTICS

(T_A = 25°C unless otherwise noted)

| Symbol | Parameter |
|------------------|----------------------------------------------------|
| I _{PP} | Maximum Reverse Peak Pulse Current |
| V _C | Clamping Voltage @ I _{PP} |
| V _{RWM} | Working Peak Reverse Voltage |
| I _R | Maximum Reverse Leakage Current @ V _{RWM} |
| V _{BR} | Breakdown Voltage @ I _T |
| I _T | Test Current |
| P _{pk} | Peak Power Dissipation |
| C | Capacitance @ V _R = 0 and f = 1.0 MHz |

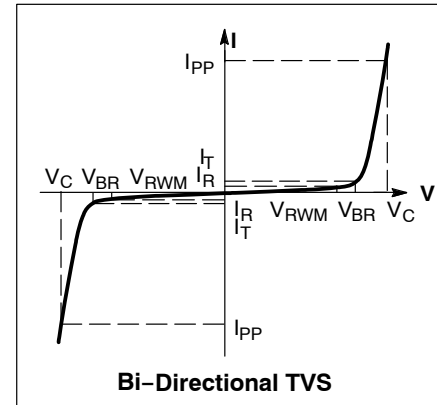

ELECTRICAL CHARACTERISTICS

| Part Numbers | V _{BR} | | @I _R | V _{RWM} | I _{RM} | V _C | | IPP | C | |
|------------------|-----------------|------|-----------------|------------------|-----------------|----------------|-------|-----|-----|-----|
| | Min. | Max. | | | | @ 1 A | @ 5 A | | Typ | Max |
| | v | v | mA | v | μA | v | v | A | pF | pF |
| LTVS23LH5.0CLT1G | 6 | 8 | 1 | 5 | 0.5 | 9.8 | 11 | 17 | 4 | 5 |

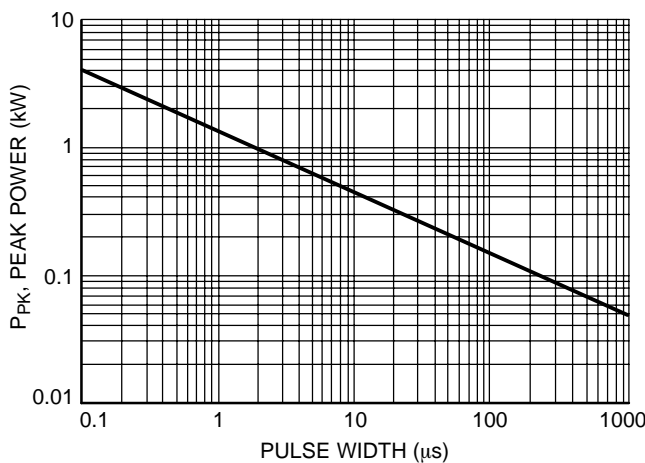

Figure 1. Maximum Peak Power Rating

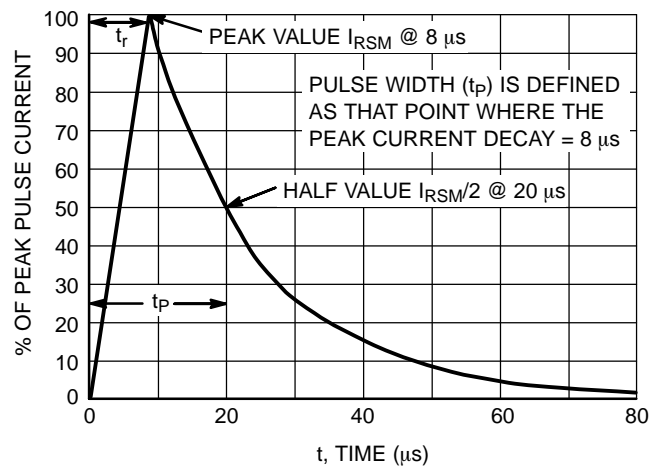
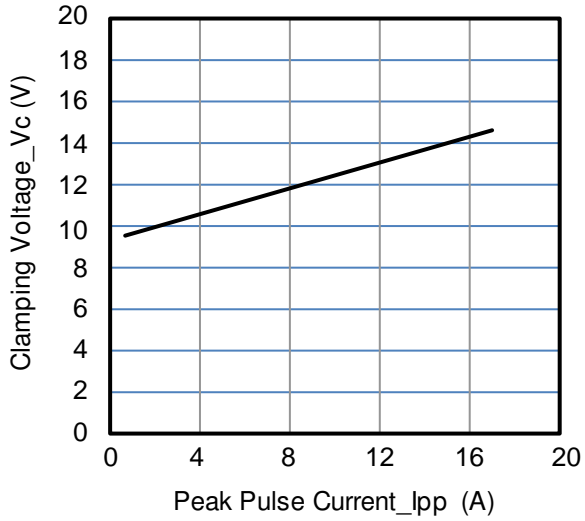
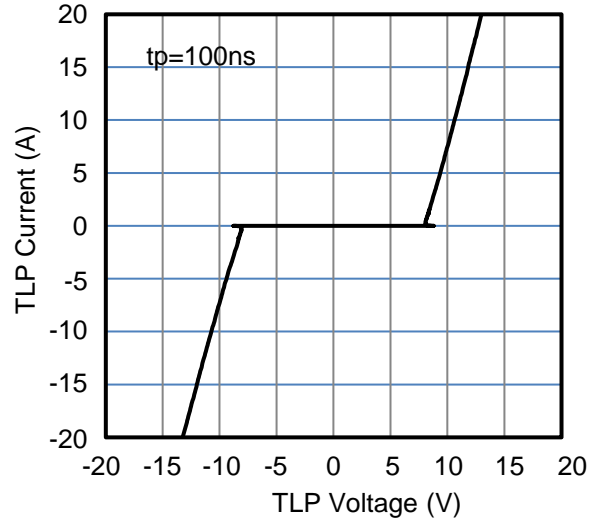
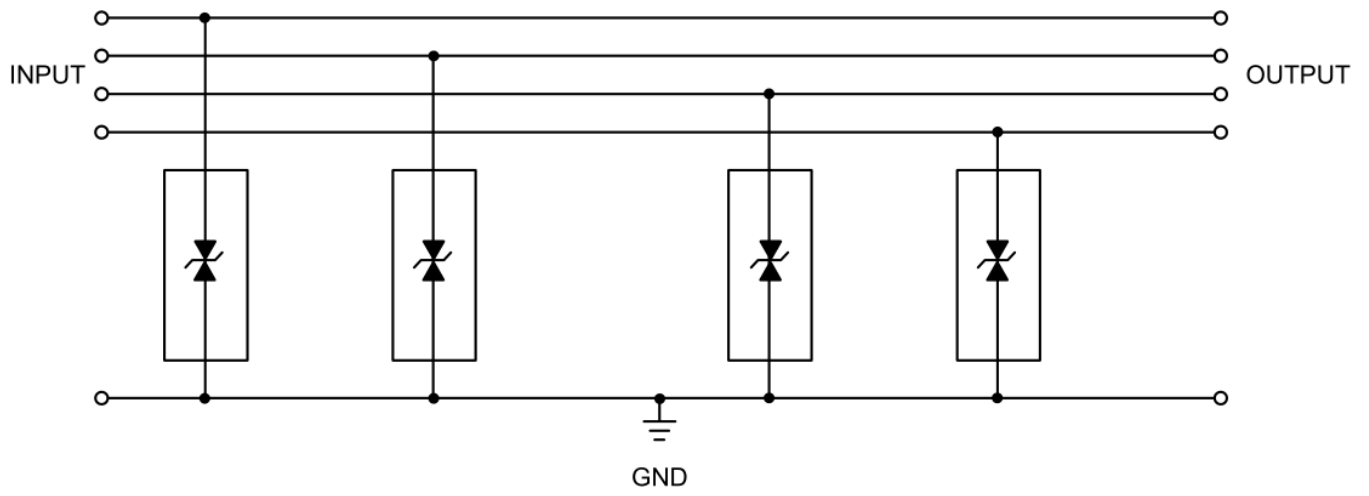

Figure 2. 8/20 μs Pulse Waveform

LTVS23LH5.0CLT1G**Fig 3. Clamping Voltage vs. Peak Pulse Current****Fig 4. TLP Measurement**

LTVS23LH5.0CLT1G

LTVS23LH5.0CLT1G

OUTLINE AND DIMENSIONS

Notes:

1. DIMENSIONING AND TOLERANCING PER ANSI Y14.5M, 1982.
2. CONTROLLING DIMENSION: MILLIMETERS.
3. MAXIMUM LEAD THICKNESS INCLUDES LEAD FINISH. MINIMUM LEAD THICKNESS IS THE MINIMUM THICKNESS OF BASE MATERIAL.
4. DIMENSIONS D AND E DO NOT INCLUDE MOLD FLASH, PROTRUSIONS OR GATE BURRS.

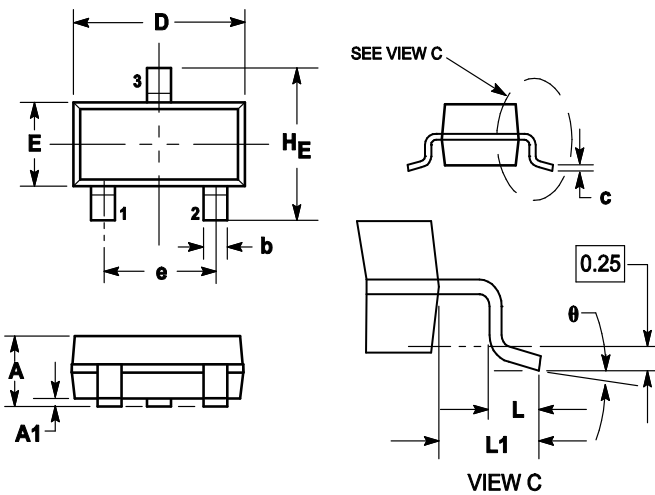

| DIM | MILLIMETERS | | | INCHES | | |
|----------|-------------|------|------|--------|-------|-------|
| | MIN | NOM | MAX | MIN | NOM | MAX |
| A | 0.89 | 1 | 1.11 | 0.035 | 0.04 | 0.044 |
| A1 | 0.01 | 0.06 | 0.1 | 0.001 | 0.002 | 0.004 |
| b | 0.37 | 0.44 | 0.5 | 0.015 | 0.018 | 0.02 |
| c | 0.09 | 0.13 | 0.18 | 0.003 | 0.005 | 0.007 |
| D | 2.80 | 2.9 | 3.04 | 0.11 | 0.114 | 0.12 |
| E | 1.20 | 1.3 | 1.4 | 0.047 | 0.051 | 0.055 |
| e | 1.78 | 1.9 | 2.04 | 0.07 | 0.075 | 0.081 |
| L | 0.10 | 0.2 | 0.3 | 0.004 | 0.008 | 0.012 |
| L1 | 0.35 | 0.54 | 0.69 | 0.014 | 0.021 | 0.029 |
| HE | 2.10 | 2.4 | 2.64 | 0.083 | 0.094 | 0.104 |
| θ | 0° | --- | 10° | 0° | --- | 10° |

SOLDERING FOOTPRINT

