

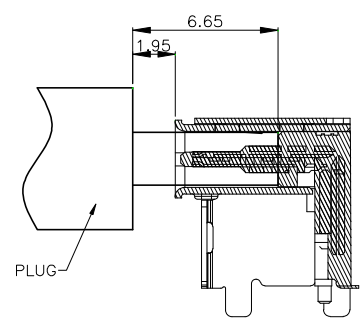

REV.	ECN NO OR DESCRIPTION	REVISED	DATE

A

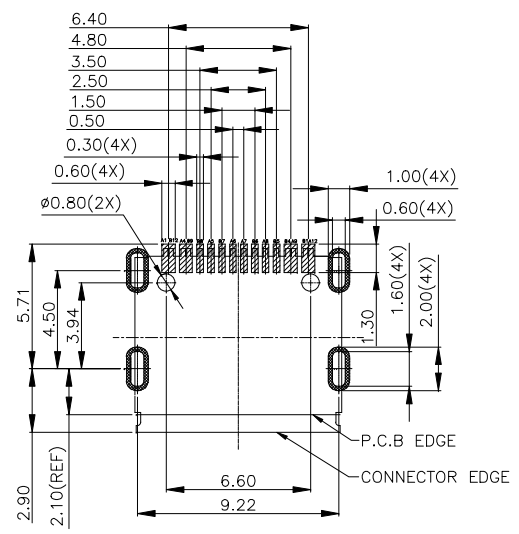
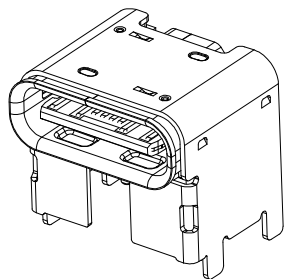
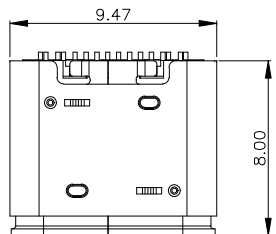

AFTER MATING

NOTE:
 1.MATERIAL SPECIFICATION:
 1.HOUSING:HIGH TEMPERATURE RESISTANT PLASTIC,UL94 V-0.
 2.TERMINAL:COPPER ALLOY (C1814)
 3.MID PLATE: STAINLESS STEEL (SUS301)
 4.FRONT SHELL: STAINLESS STEEL (SUS304)
 5.TOP SHELL: STAINLESS STEEL (SUS304)
 2.PLATING SPECIFICATION:
 2-1.CONTACTS:
 Ni 50u" MIN. UNDER PLATED OVER ALL.
 Au PLATED ON THE FUNCTIONAL AREA OF CONTACT.
 (GOLD PLATING THICKNESS FOLLOW THE P/N)
 PLATING SPECIFICATIONS OF THE SOLDER AREA FOLLOW THE P/N
 2-2.FRONT SHELL&TOP SHELL:
 Ni 30u" MIN. UNDER PLATED OVER ALL.
 2-3.MID PLATE:
 CLEAR ONLY
 3.MECHANICAL PERFORMANCE,
 3-1.INSERTION FORCE: 0.5~2.0kgf.
 3-2.REMOVAL FORCE: 0.8kgf~2.0kgf.
 3-3.DURABILITY: 10000 CYCLES.
 4.ELECTRICAL PERFORMANCE,
 4-1. VOLTAGE RATING:5 V DC/AC (RMS. max)
 CURRENT RATING:5 AMPS. FOR TOTAL VBUS/GND PINS;
 1.25AMPS FOR CC PIN,0.25 AMPS. FOR ALL OTHER CONTACT.
 4-2. LLCR:
 VBUS & GND PINS AND OTHER PINS: 40mA/PIN MAX.
 SHIELD: 50mA/MAX.
 LLCR MAX. CHANGE OF ALL PINS: 10mA.
 4-3.INSULATION RESISTANCE: 100MΩ MIN
 4-4.DIELECTRIC WITHSTAND VOLTAGE,AC 100V FOR 1 MINUTE.
 5. ENVIRONMENTAL PERFORMANCE:
 OPERATING TEMPERATURE: -25°C~+85°C.
 6.IR REFLOW:
 THE PEAK TEMPERATURE ON THE BOARD SHALL
 BE MAINTAINED FOR 10 SECONDS AT 260°C.

B

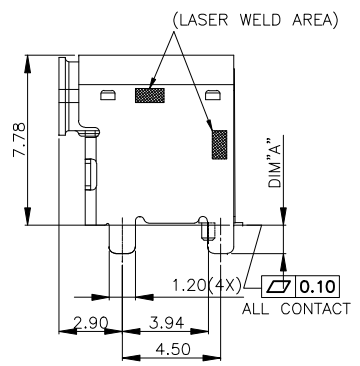
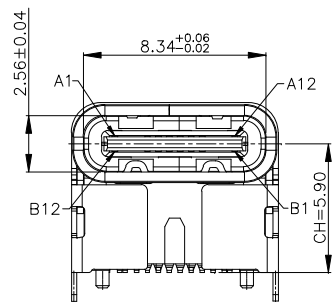

RECOMMENDED PCB LAYOUT(TOP VIEW)

USB TYPE-C PIN ASSIGNMENTS

PIN NUMBER	SIGNAL NAME	PIN NUMBER	SIGNAL NAME
A1	GND	B12	GND
A4	Vbus	B9	Vbus
A5	CC1	B8	SBU2
A6	Dp1	B7	Dn2
A7	Dn1	B6	Dp2
A8	SBU1	B5	CC2
A9	Vbus	B4	Vbus
A12	GND	B1	GND

C

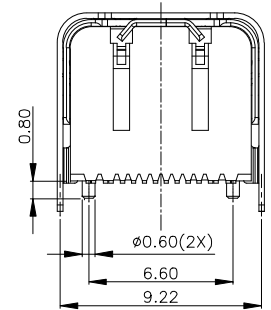
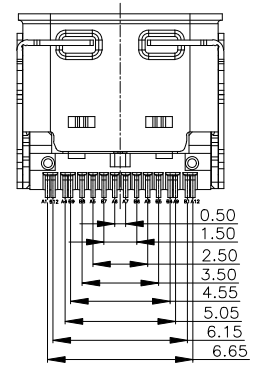

D

UNLESS OTHERWISE SPECIFIED TOLERANCES		东莞市汉博电子科技有限公司 DONGGUAN HANBO TECHNOLOGY CO., LTD			
DECIMALS:	ANGLES:	TITLE	USB C F TYPEC 16PIN SMT CH=5.9		
X :±0.35	X :±2°	DWN	xiong	PART NO. MC-108	
X.X :±0.25	X.X :±1°	CHKD	lee	SCALE:1:1	UNIT: mm
X.XX :±0.15		APVD	wang	SIZE: A4	SHEET:1OF 1
CUSTOMER COPY					

1

2

3

4

5

6



REV.	ECN NO OR DESCRIPTION	REVISED	DATE

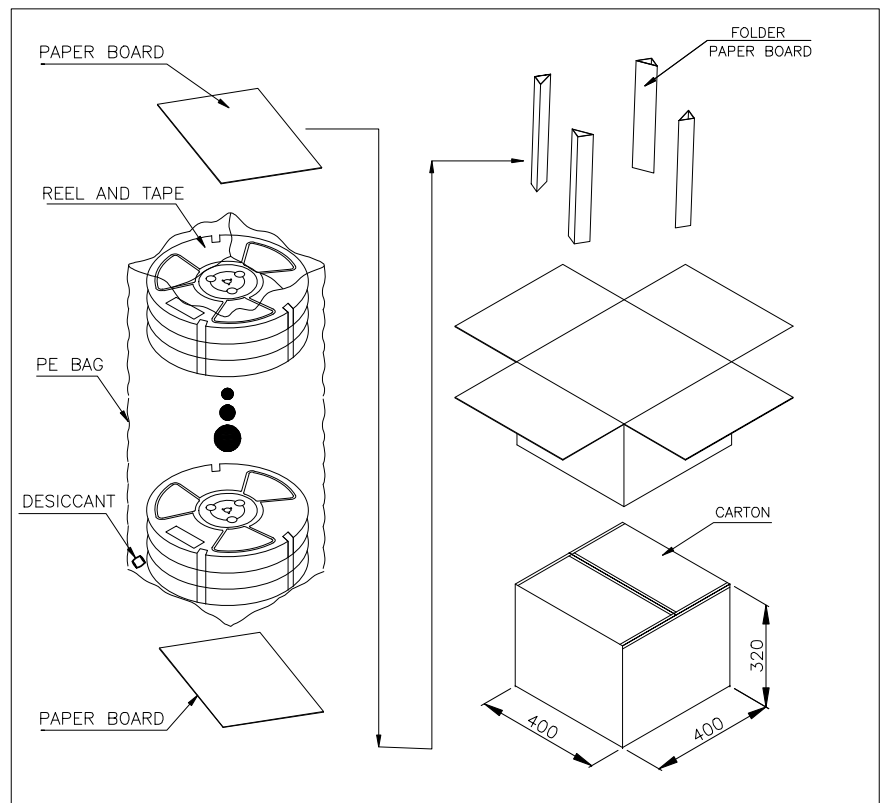
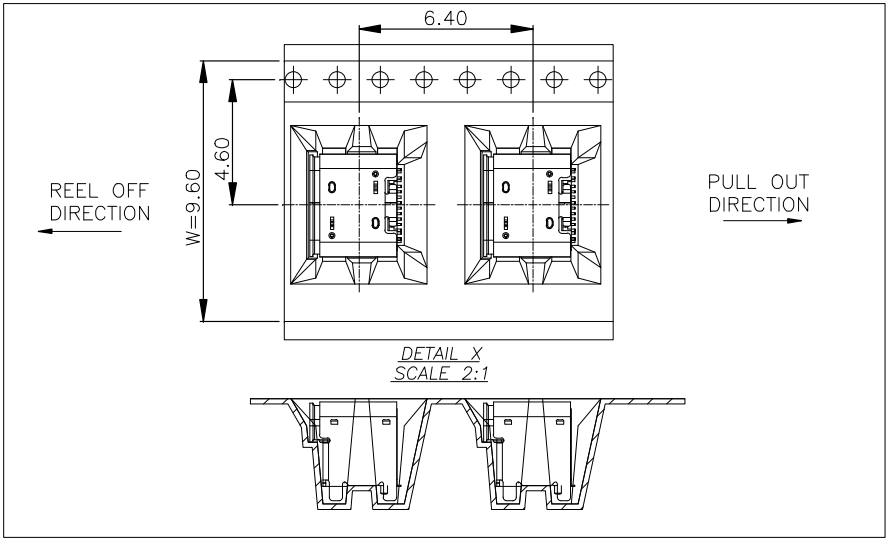
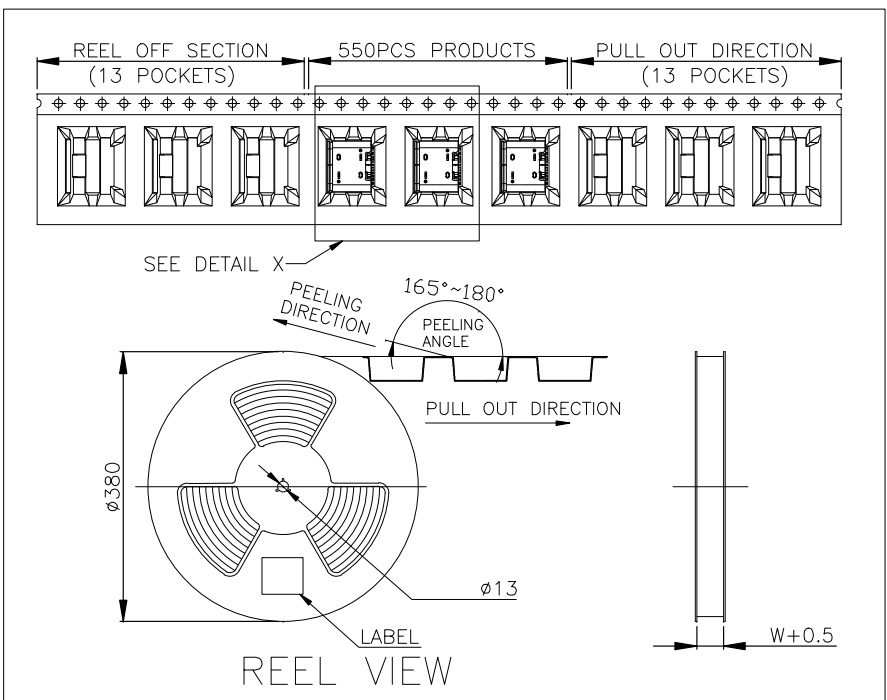

	REEL	CARTON
CONNECTOR (PCS)	550	5500
UNLESS OTHERWISE SPECIFIED TOLERANCES	东莞市汉博电子科技有限公司 DONGGUAN HANBO TECHNOLOGY CO., LTD	
DECIMALS: X :±0.35	TITLE USB C F TYPEC 16PIN SMT CH=5.9	
X :±2°	DWN xiong PART NO. MC-108	
X.X :±0.25	CHKD lee SCALE:1:1	UNIT: mm
X.XX :±0.15	APVD wang SIZE: A4	SHEET:10F 1
		REV: A4
	CUSTOMER COPY	