

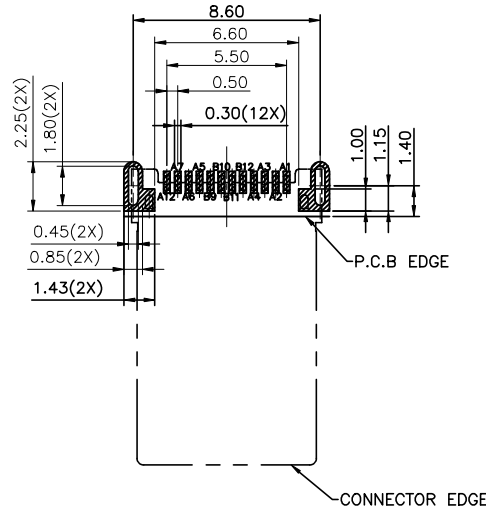

REV.	ECN NO OR DESCRIPTION	REVISED	DATE

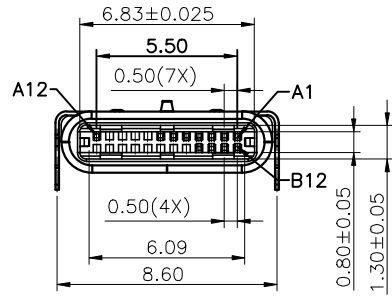

RECOMMENDED PCB LAYOUT(TOP VIEW)
TOLERANCE: ±0.05

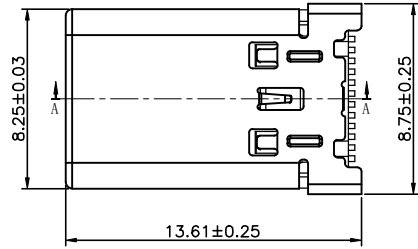
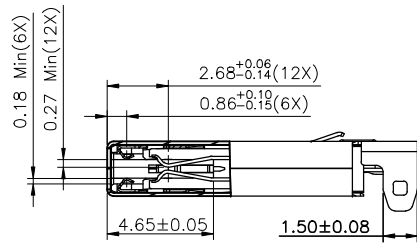

SECTION:A-A
SCALE 1:1

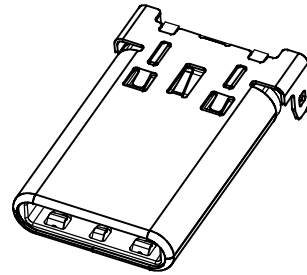

- NOTE:
- MATERIAL SPECIFICATION:
 - HOUSING:HIGH TEMPERATURE RESISTANT PLASTIC,UL94 V-0.
 - CONTACTS:COPPER ALLOY
 - MID PLATE: STAINLESS STEEL
 - FRONT SHELL: STAINLESS STEEL
 - EMI PLATE: STAINLESS STEEL
 - PLATING SPECIFICATION:
 - CONTACTS:
 - Ni 50u" MIN. UNDER PLATED OVER ALL.
 - Au PLATED ON THE FUNCTIONAL AREA OF CONTACT. (GOLD PLATING THICKNESS FOLLOW THE P/N)
 - 80u" MIN TIN PLATED ON SOLDER AREA.
 - FRONT SHELL:
 - Ni 30u" MIN. UNDER PLATED OVER ALL.
 - MID PLATE:
 - Ni 50u" MIN. UNDER PLATED OVER ALL.
 - EMI PLATE:
 - CLEAR ONLY
 - MECHANICAL PERFORMANCE,
 - INSERTION FORCE: 0.5~2.0kgf.
 - REMOVAL FORCE: 0.8kgf~2.0kgf.
 - DURABILITY: 10000 CYCLES.
 - ELECTRICAL PERFORMANCE,
 - CURRENT RATING:5.0A
VOLTAGE RATING:5.0V
 - LLCR:
 - VBUS & GND PINS AND OTHER PINS: 40mA/PIN MAX.
 - SHIELD: 50mA/MAX.
 - LLCR MAX. CHANGE OF ALL PINS: 10mA.
 - INSULATION RESISTANCE: 100MΩ MIN
 - DIELECTRIC WITHSTAND VOLTAGE,AC 100V FOR 1 MINUTE.
 - ENVIRONMENTAL PERFORMANCE:
 - OPERATING TEMPERATURE: -25°C~+85°C.
 - IR REFLOW:
 - THE PEAK TEMPERATURE ON THE BOARD SHALL BE MAINTAINED FOR 10 SECONDS AT 260°C.

USB TYPE-C PIN ASSIGNMENTS

PIN NUMBER	SIGNAL NAME	PIN NUMBER	SIGNAL NAME
A1	GND	B12	GND
A2	SSTXp1	B11	SSRXp1
A3	SSTXn1	B10	SSRXn1
A4	Vbus	B9	Vbus
A5	CC1	B8	
A6	Dp1	B7	
A7	Dn1	B6	
A8		B5	
A9		B4	
A10		B3	
A11		B2	
A12	GND	B1	

TABLE 1

ITEM	P/N	HOUSING COLOR	CONTACTS	
			FUNCTIONAL AREA	SOLDER AREA
1	TC-002D	BLACK	Au:1u"	Sn 80u"
UNLESS OTHERWISE SPECIFIED TOLERANCES		东莞市汉博电子科技有限公司 DONGGUAN HANBO TECHNOLOGY CO., LTD		
DECIMALS: X ±0.30, X.X ±0.20, X.XX ±0.10		TITLE: USB TYPE C SMT PLUG DIP SHELL		
ANGLES: X ±2°, X.X ±1°		DWN xiong PART NO. TC-002D		
		CHKD lee SCALE:1:1 UNIT: mm		
		APVD wang SIZE: A4 SHEET:10F 1 REV: A4		
CUSTOMER COPY				

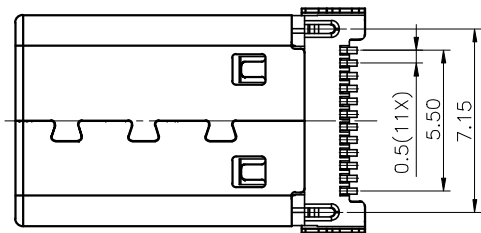
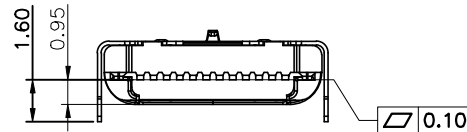
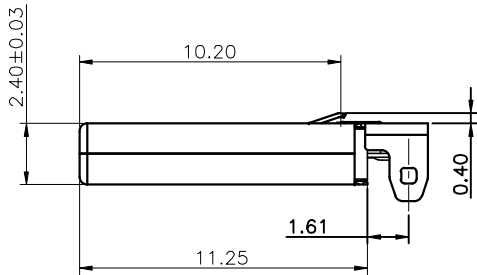



REV.	ECN NO OR DESCRIPTION	REVISED	DATE

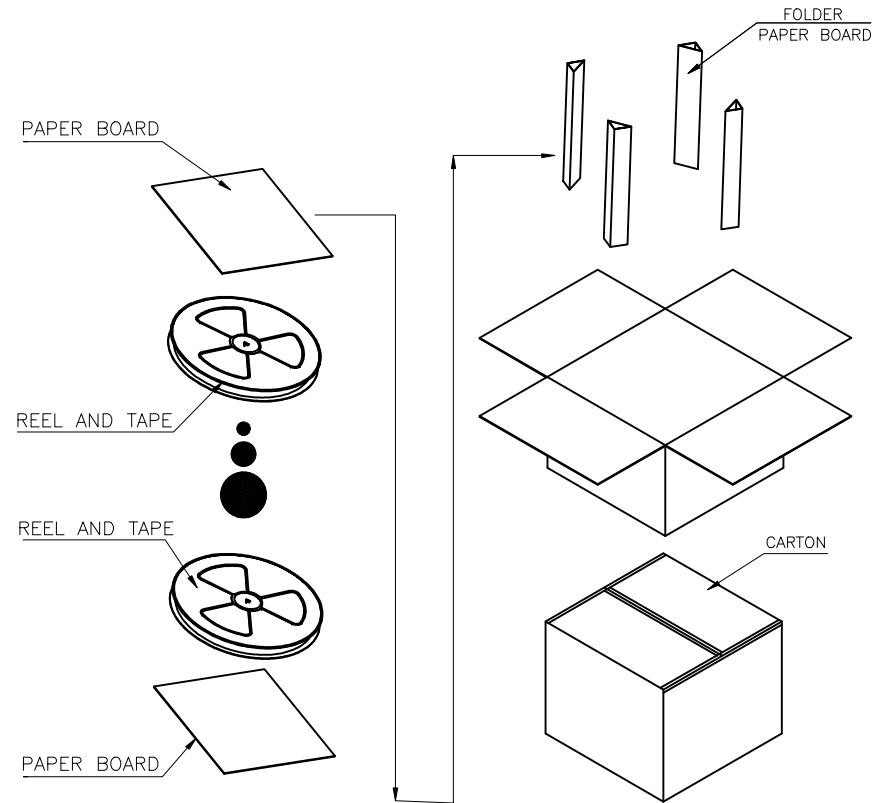
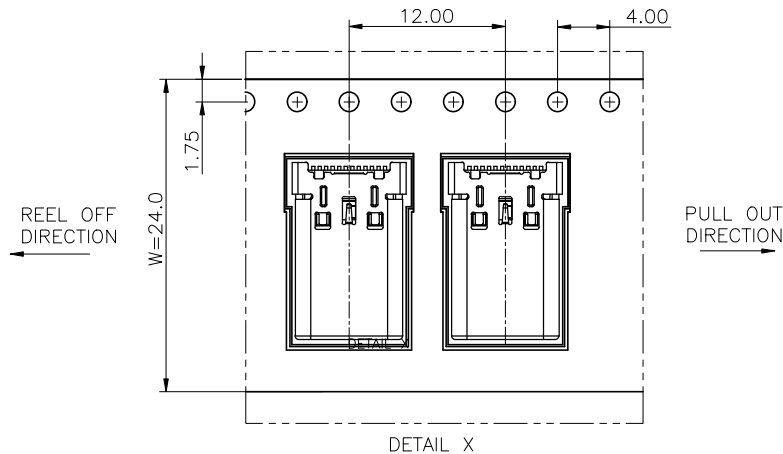
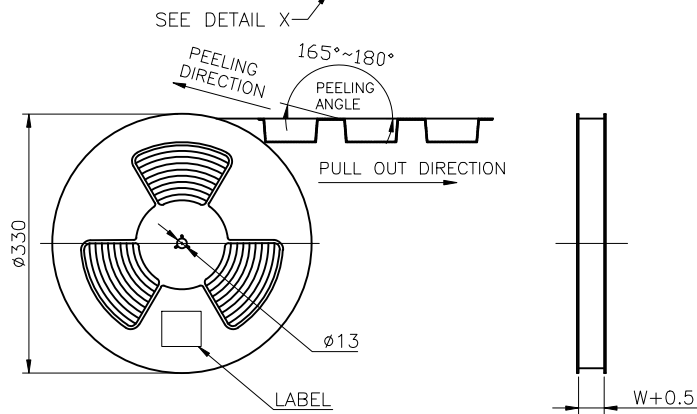
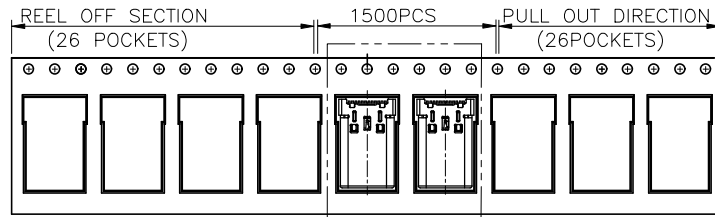

	REEL	CARTON
CONNECTOR (PCS)	1500	15000

UNLESS OTHERWISE SPECIFIED TOLERANCES

DECIMALS:	ANGLES:
X :±0.30	X :±2°
X.X :±0.20	X.X :±1°
X.XX :±0.10	

东莞市汉博电子科技有限公司
DONGGUAN HANBO TECHNOLOGY CO., LTD

TITLE	USB TYPE C SMT PLUG DIP SHELL			
DWN	xiong	PART NO. TC-002D		
CHKD	lee	SCALE:1:1	UNIT: mm	
APVD	wang	SIZE: A4	SHEET:1OF 1	REV: A4

CUSTOMER COPY