

REV.	ECN NO.	DATE	SIGN	DESCRIPTION
B	LEN1390081	2013/05/25	Tony_leng	Change 5.5 To 5.7
C	C200380	2020/03/30	JC Chen	△C XI

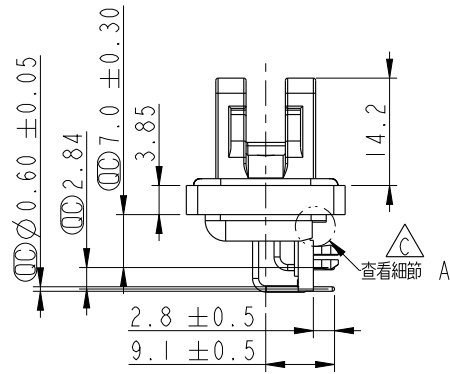
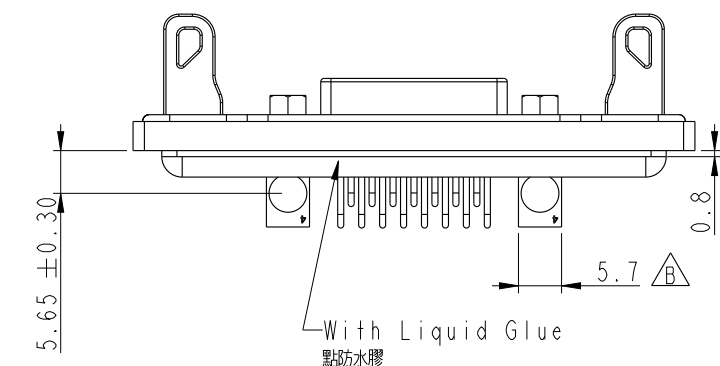
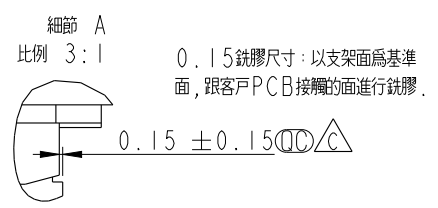
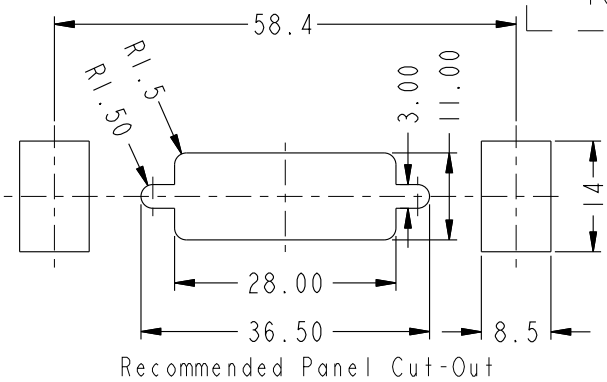
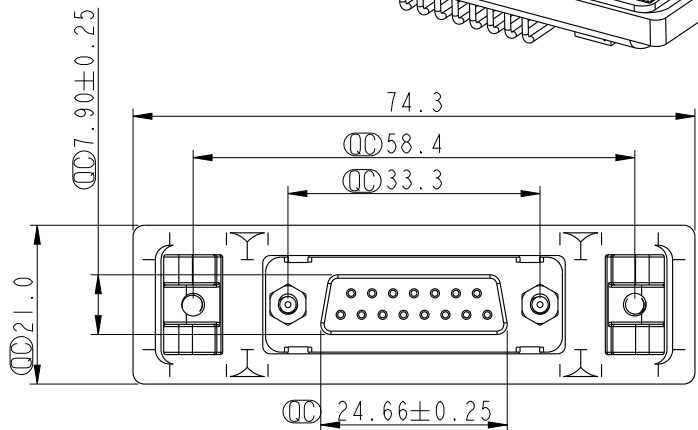
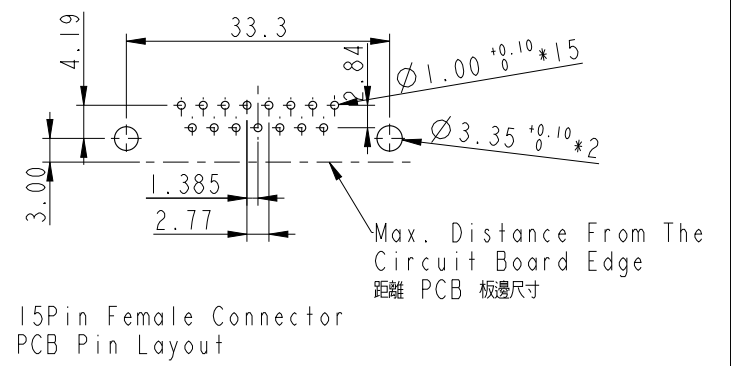
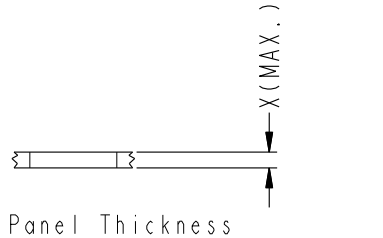
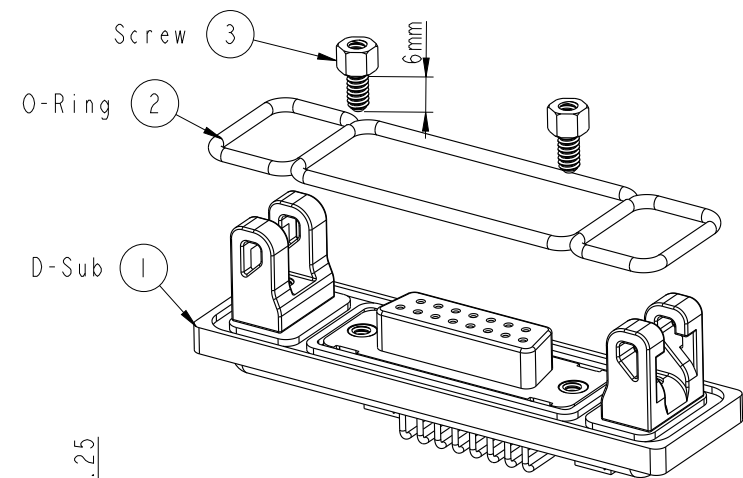

- Notes:
- \*  $\text{CC}$  Important Dimension.
  - \* Materials:
    - Panel : Zinc
    - Panel Link : Zinc
    - Screw : Stainless, #4-40 UNC
    - O-Ring : Silicone Black
    - Insulator : PBT
    - Shell : Cold Rolled Steel
    - Contact : Copper Alloy
    - Board Lock : Copper Alloy
  - \* Finishes:
    - Panel : Nickel Plated
    - Panel Link : Nickel Plated
    - Board Lock : Nickel Plated
    - Shell : Nickel Plated
    - Contact : Gold Flash
  - \* Waterproof Rate : IP68  
IP68: 1M of depth of water 24 hours

UNIT: mm		TITLE D-SUB CONN PANEL QUICK DBI5P F CONN F PIN
TOLERANCE .X ±0.25 .XX ±0.1 .XXX ±0.05 ANGLES ±1°	SCALE 1:1	SIZE A4
	REV. C	SHEET 1 OF 1
	WC-REV. A.5	QC: Inspection item

**Amphenol LTW**  
安費諾亮泰企業股份有限公司

ITEM NO SDB-15PFFP-QB8001	DRAWN BY Tony_leng	DATE 2013/05/25
DWG NO SDB-15PFFP-QB8001	CHECKED BY Yulong	DATE 2013/05/25
CUSTOMER ALTW	APPROVED BY Victor	DATE 2013/05/25

THIS DOCUMENT IS SUBJECT TO CHANGE WITHOUT NOTICE. IT IS CONFIDENTIAL AND A PROPERTY OF Amphenol LTW. DISCLOSURE TO THIRD PARTY HAS TO BE AUTHORIZED BY Amphenol LTW.